



Pacific Electric Chain Hoist

U-MEGA Series

OPERATION MANUAL

&

PARTS LIST

Model

HOISTS	TROLLEYS
PEH-025, PEH-050-2	PET-050, PET-055
PEH-050, PEH-100-2	PET-100, PET-105
PEH-100	PET-200, PET-205
PEH-200	

SAFETY-IMPORTANT

The use of any hoist and trolley presents some risk of personal injury or property damage.

That risk is greatly increased if proper instructions and warnings are not followed. Before using this hoist, each user should become thoroughly familiar with all warnings, instructions and recommendations herein.



THIS SYMBOL POINTS OUT IMPORTANT SAFETY INSTRUCTIONS WHICH IF NOT FOLLOWED COULD ENDANGER THE PERSONAL SAFETY AND/OR PROPERTY OF YOURSELF AND OTHERS. READ AND FOLLOW ALL INSTRUCTIONS IN THIS MANUAL AND ANY PROVIDED WITH THE EQUIPMENT BEFORE ATTEMPTING TO OPERATE THE PACIFIC PORTA HOIST.



CONTENTS

Safety-Important.....	1
1. Foreword	3
2. Main Specification	4
2.1 Specification	4
2.2 Mechanical Classification (Grade) and Life	5
2.3 Safety Devices	6
2.4 Specifications and Dimensions	7
3. Safety Rules	9
4. Installation	11
4.1 Unpacking Information	11
4.2 Voltage	11
4.3 Installation	11
5. Operation	14
6. Maintenance and Inspection	15
6.1 Maintenance	15
6.2 Inspection	15
7. Troubleshooting	19
7.1 Wiring Diagrams	19
7.2 Troubleshooting and Remedial Action	22
8. Drawings and Parts Lists	23
9. CE Declaration Of Conformity	36

1. FOREWORD

This manual contains important information to help you properly install, operate and maintain the electric chain hoist for maximum performance, economy and safety.

Please study its contents thoroughly before putting the Pacific Porta Hoist into operation. By practicing correct operation, procedures and by carrying out the preventative maintenance recommendations, you will be assured of dependable service. In order to help us to supply correct spare parts quickly, please always specify,

1. Hoist model
2. Serial number
3. Part number, plus the description.

We trust that you will find the Pacific Porta Hoist will give you many years of satisfactory service.

Should you have any queries, please contact:

Pacific Hoists - Head Office	Pacific Hoists - WA	Pacific Hoists - NZ
24 Foundry Road	3/39 Tulloch Way	11 Druces Road
Seven Hills NSW 2147	Canning Vale WA 6970	Manukau City, Sth Auckland NZ
Ph: 02 8825 6900	Ph: 08 9456 4140	Ph: 9 263 5566
Fax: 02 8825 6999	Fax: 08 9456 4142	Fax: 9 263 5567

2.MAIN SPECIFICATIONS

2.1 Specifications

Table 2-1 Specifications

Item		Detail	
Working temperature range (°C)		-5 to +40	
Working humidity range (%)		85 or less	
Protection	Hoist	IP 54	
	Push button	IP 65	
Electric power supply		Three Phase, 415V, 50 Hz	
Noise Level (dB)	Dual speed hoist	75	
Chain Size	Type	Nominal diameter (mm)	Pitch (mm)
	PEH-025/PEH-050-2	4.0	12.0
	PEH-050/PEH-100-2	6.3	19.1
	PEH-100/PEH-200	7.1	20.2

NB. Reverse phase relay on all models except 250kg hoist

Remarks:

- (1) Contact an authorized U-MEGA dealer for information on using the hoist outside the working temperature or humidity range.
- (2) Intended use: This hoist has been designed for vertically lifting and lowering loads under normal atmospheric conditions.
- (3) Noise levels are measured at a distance of 1m horizontally from the hoists during normal operation.

2.2 Mechanical Classification (Grade) and Lift

Safety and life of electric chain hoists are guaranteed only when the equipment is operated in accordance with the prescribed grade.

U-MEGA electric chain hoists have been designed for grade 2m in the FEM Regulations (FEM 9.5.11). Details are provided in Table 2-2. Average daily operating time and total operating time are determined by load distribution.

Table 2-2 Mechanical classification

Load Spectrum (Load distribution)	Definitions	Cubic mean value	Average daily Operation time (h)	Total operating time (h)
1 (light)	Mechanisms or parts thereof, usually subject to very small loads and in exceptional cases only to maximum loads.	$k \leq 0.50$	4 - 8	12500
2 (medium)	Mechanisms or parts thereof, usually subject to small loads but rather often to maximum loads.	$0.50 < k \leq 0.63$	2 - 4	6300
3 (heavy)	Mechanisms or parts thereof, usually subject to medium loads but frequently to maximum loads.	$0.63 < k \leq 0.80$	1 - 2	3200
4 (very heavy)	Mechanisms or parts thereof, usually subject to maximum of almost maximum loads.	$0.80 < k \leq 1.00$	0.5 - 1	1600

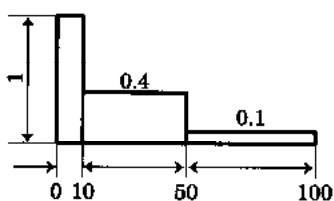

% operating time
Load spectrum 1

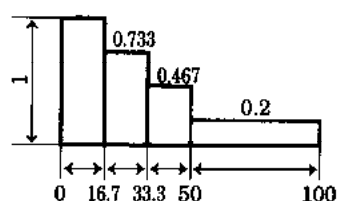

% operating time
Load spectrum 2

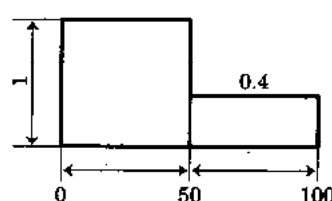

% operating time
Load spectrum 3

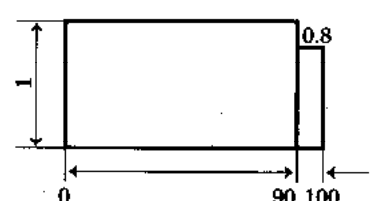

% operating time
Load spectrum 4

2.3 Safety Devices

(1) Motor brake

The “Electro-Magnetic Brake” is of a unique design in its field. It features simultaneous motor braking upon switching off power even under full load condition.

(2) Hook and hook latch

The hook is drop-forged from high tensile steel and heat treated for strength and toughness. The bottom hook is capable of 360° swivel and fitted with a safety latch for added security.

(3) Overload protection device

Overload protection device in the form of a slipping clutch prevents damage due to overloading.

(4) Limit switches

Upper and lower limit switches are fitted for switching off power automatically in case of over lifting or over lowering.

(5) Emergency stop device

This button is used to stop the hoist in an emergency situation. It is a red, mushroom type button, located in the uppermost position on the pendant. When pressed, power to the equipment is switched off and the button locks automatically. Turning it to the right will release the lock and to enable re-starting. (Illust. 1)

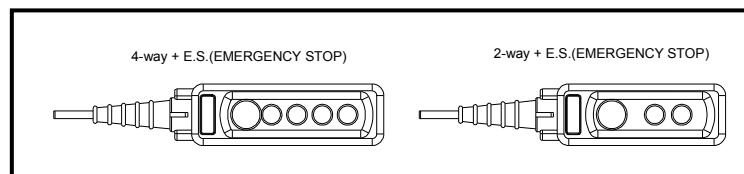

Illust. 1

2.4 Specifications and Dimensions

a. Specifications:

Capacity (kg)	250	500	500	1000	1000	2000	
Lift Height(m)	3etc.						
Load Chain (mm)	Φ4.0×12.0	Φ4.0×12.0	Φ6.3×19.1	Φ6.3×19.1	Φ7.1×20.2	Φ7.1×20.2	
Dual Speed (m/min)	50HZ	12/3	6/1.5	10/2.5	5/1.25	8/2	4/1
Motor Power (kw)	50HZ	0.6/0.15		1.1/0.28		1.5/0.37	
Motorized Trolley Mode N.W./G.W.(kg)	68/84	72/88	80/98	90/108	106/131	111/136	
Top Hook Mode N.W./G.W.(kg)	30/42	32/44	42/57	45/60	57/77	62/82	
Power Supply	3Phase, 415V,50Hz						
E.D. Rating (%)	40/20						
Load Chain Fall Number	1	2	1	2	1	2	

b. Dimensions:

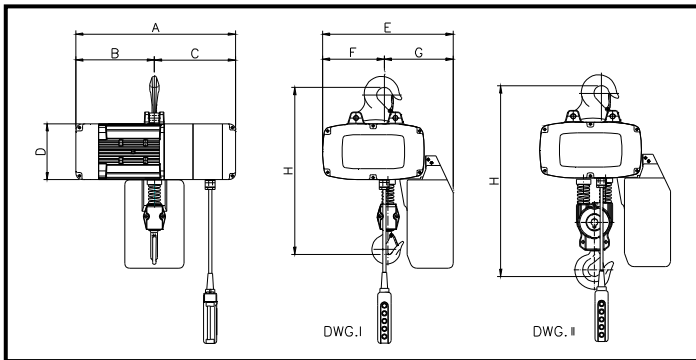

Hoist

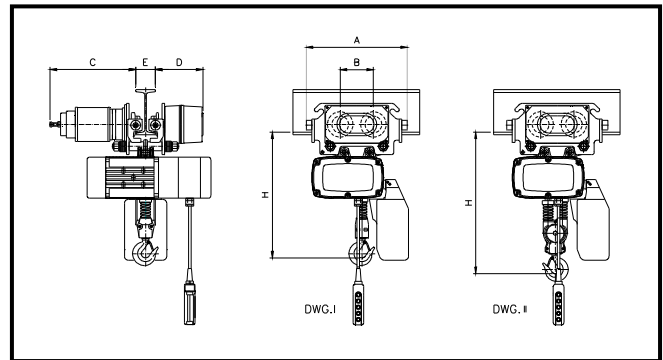

Hoist + Torley

Model	DWG.	Dimensions(mm)							
		A	B	C	D	E	F	G	H
PEH-025	I	380	175	205	135	299	143	156	376
PEH-050-2	II								453
PEH-050	I	468	221	247	156	366	186	180	485
PEH-100-2	II								531
PEH-100	I	487	240	248	170	398	188	210	520
PEH-200	II								592

Model	DWG.	Dimensions(mm)						
		A	B	C	D	E	H	
PEH-025+PET-050(055)	I	382	125.5	324	180	75~125	358	
PEH-050-2+PET-050(055)-2	II						462	
PEH-050+PET-050(055)	I	382	125.5	324	180	75~125	483	
PEH-100-2+PET-100(105)-2	II						542	
PEH-100+PET-100(105)	I	382	125.5	324	180	75~125	510	
PEH-200+PET-200(205)	II						582	

c.Specifications:

Model	Speed (m/min)	Motor (kw)	N.W. (kg)	Min radius of carve(m)
PET-050	20	0.12 2P	45	1.3
PET-055	20/5	0.12/0.03 2/8P		
PET-050-2	20	0.12 2P	45	1.3
PET-055-2	20/5	0.12/0.03 2/8P		
PET-100	20	0.18 2P	45	1.3
PET-105	20/5	0.18/0.04 2/8P		
PET-100-2	20	0.18 2P	45	1.3
PET-105-2	20/5	0.18/0.04 2/8P		
PET-200	20	0.37 2P	50	1.7
PET-205	20/5	0.37/0.09 2/8P		

d. Dimensions:

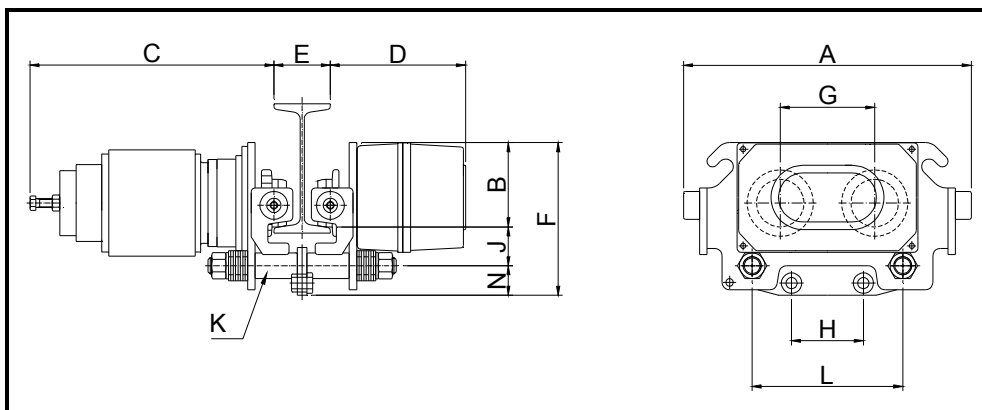

Trolley

Model	Dimensions(mm)											
	A	B	C	D	E	F	G	H	L	J	N	K
PET-050	382	111.5	324	180	75~	202	125.5	95.5	200	51.5	39	7/8"-9UNC (ϕ 22.2)
PET-055					125							
PET-050-2	382	111.5	324	180	75~	204	125.5	120	200	51.5	41	7/8"-9UNC (ϕ 22.2)
PET-055-2					125							
PET-100	382	111.5	324	180	75~	202	125.5	120	200	51.5	39	7/8"-9UNC (ϕ 22.2)
PET-105					125							
PET-100-2	382	111.5	324	180	75~	202	125.5	95.5	200	51.5	39	7/8"-9UNC (ϕ 22.2)
PET-105-2					125							
PET-200	392	125	357	183	100~	221	159	120	230	60	36	1"-8UNC (ϕ 25.4)
PET-205					150							

3. SAFETY RULES



This hoist is not designed for, and should not be used for, lifting, supporting, or transporting personnel. Any modifications to upgrade, re-rate, or otherwise alter the hoist equipment must be authorized by either the original manufacturer or a qualified professional engineer.

Do not use the hoist in explosive atmosphere.

Only trained personnel are allowed to operate the hoist.

Prior to each lifting operation, it is essential to make sure that:

- (a) the correct lifting sling is being used.
- (b) the lifting sling is located in the hook as shown below (Illust. 2) and that a safety latch has been fitted.

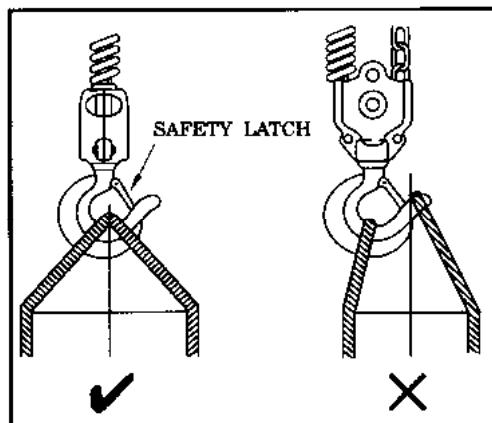

(Illust. 2)

Firm and steady button operation is required. Never push the button switch intermittently.

Always avoid excessive inching operation.

Always make sure the hoist motor completely stops before reversing.

Always leave the pendant button switch cable and bottom hook load chain vertically static after completion of operation, never leave them at any position, which may allow them to swing or slip.

Slings must be applied to load evenly and centrally to ensure correct balance. Never lift any object which is insecure or out of balance.

Never use hoist to end or side pull a load. (Illust. 3)

Never wrap around and hook back the load chain as a sling to lift a load. (Illust. 4)

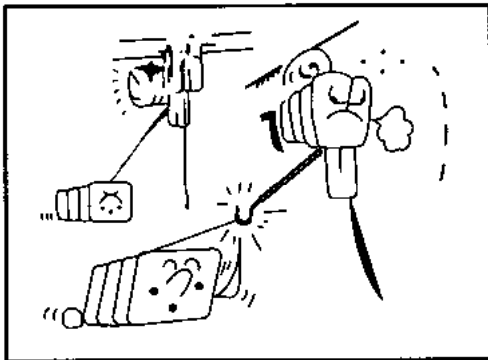

Illust. 3

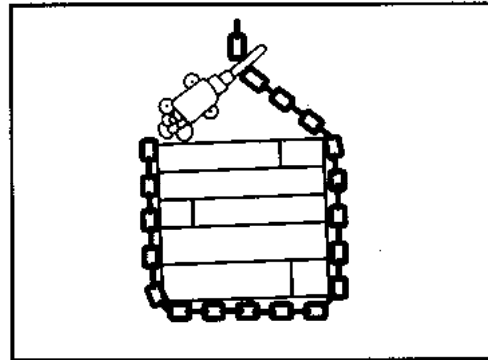

Illust. 4

Do not use the hoist chain as a welding electrode.

Never stand under a raised load (Illust. 5)

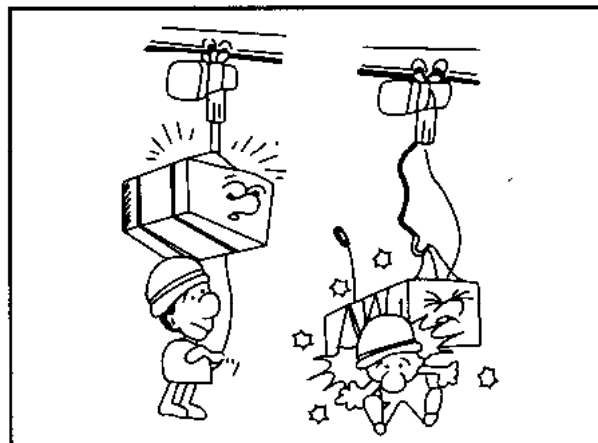

Lifting must always be personally attended. Never leave a raised load unattended.

Over-capacity-load lifting is hazardous and should not be undertaken.

Never lift a load when the load chain is twisted.

Regularly inspect and check the condition of load chain. Do not operate with damaged chain.

4. INSTALLATION

4.1 Unpacking Information

After removing the hoist from its packing box, carefully inspect the external condition of the electrical cables, contactor, gearbox and motor casing for damage.

Check and ensure that these items are present.

Each hoist is supplied as standard with the following accessories.

1. Chain bucket	1 set
2. Power cable	5 metre
3. Push button control switch	1 piece

Table. 4-1

4.2 Voltage



CAUTION

If power supply deviates from standard by more than $\pm 10\%$ abnormal operation or damage to the motor may result. It is imperative to ensure correct voltage supply before commencing operation.

4.3 Installation



WARNING

Connection to power supply before installation procedures having been completed is strictly prohibited.

Prior to installation check and ensure that the top hook assembly is securely attached to the hoist by means of the lock bolt.

NOTE: If the hoist is to be suspended from an electric trolley, assembly may be eased by firstly removing the top hook, attaching it to the trolley load plate, then refitting the top hook to the hoist.



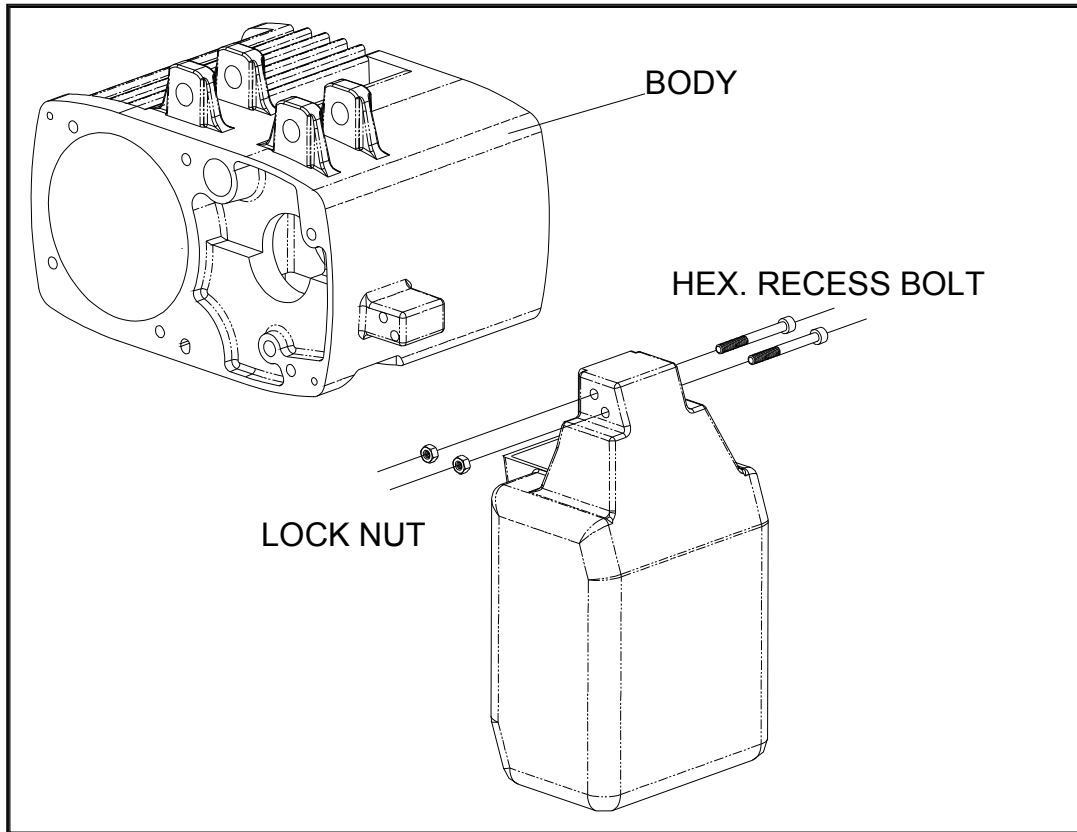

Assemble chain bucket -

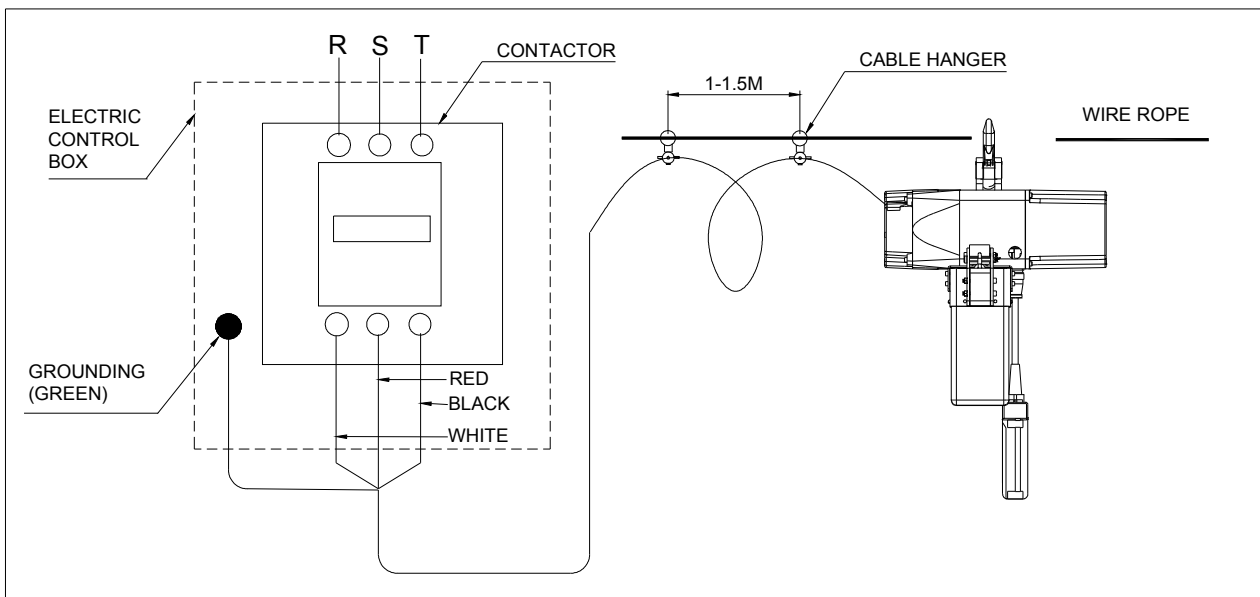

Connect power supply to hoist and operate the push button switch. This operation must be carried out by a trained person.



Operation Test

- (a) Firmly push  switch button to lower load chain until the limit spring touches the limit switch. Power should be cut off automatically.
- (b) Firmly push  switch button to check the collection of load chain into chain bucket.
- (c) Check the emergency stop device function :
While holding down either  or  button on the push button switch, push the emergency stop button. Check that the hook stops when the emergency stop button is pushed. Also, check the hoist does not move in response to the push button switch. Finally, check that the emergency stop device pops out when turned to the right and that operation can be resumed thereafter. If the equipment fails to pass any of the above checks, check the wiring and automatic locking function of the emergency stop device.
- (d) Check load chain lubrication (It has been lubricated at our works, but the lubricant may dry out during transportation). It is also advisable to keep a small amount of lubricant in the chain bucket to keep the chain in an oil bath.
- (e) Check chain position. Weld joints on links must face the same direction (Illust. 8). Correct chain operation can only be achieved when all joints are vertically in line.

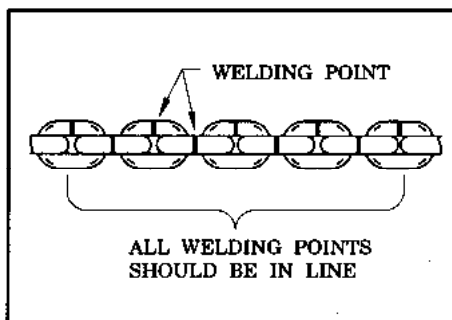

Illust. 8

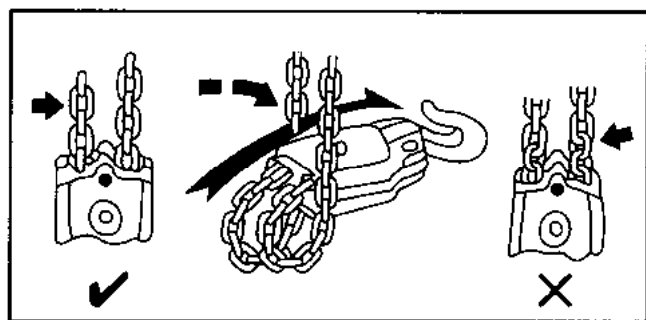

Illust. 9

5. OPERATION

After running test and checks have been completed, the hoist will be ready for normal operation.



WARNING

Since dealing with heavy loads may involve unexpected danger all of the "SAFETY RULES" (Ref 3.) must be followed and the operator must be aware of the following points while using the hoist.

- (1) The operator must have a clear and unobstructed view of the entire working area before operating the hoist.
- (2) The operator must check that the entire working area is safe and secure before operating the hoist.
- (3) When using the hoist with a motorized trolley, the operator must take care to prevent excessive load swinging by sympathetic use of the trolley controls.

6. MAINTENANCE AND INSPECTION



DANGER

Do not perform maintenance on the hoist while it is carrying a load except monthly checking for the brake or limit switch.



DANGER

Before performing maintenance do not forget to affix tags to the power source and the push button switch reading : “DANGER”, “EQUIPMENT BEING REPAIRED”.

6.1 Maintenance

- (1) Check the level of gearbox lubricant after first 500 hours of operation, thereafter every 3 months and lubricant accordingly.

NOTE: We recommend using lubricant oil equivalent to ISO VG460.

- (2) Always keep the hoist unit dry and never misuse it in a manner likely to reduce its durability.
- (3) When it is necessary to keep the unit outdoors, a protective covering should be fitted.

6.2 Inspection

1. Daily inspection: Before starting daily operation, check the followings:

- (a) Correct power supply.
- (b) “Up”, “Down” and “Emergency Stop” (where fitted) test runs under no load.
- (c) Correct motor performance.
- (d) No abnormal or excessive noise.
- (e) No malfunction of the bottom hook safety latch.
- (f) Proper function of moving/turning parts and brake.
- (g) Well-lubricated load chain.

2. Monthly inspection

(a) Load chain.

Distorted, elongated or worn chain link will not sit properly on the load sprocket wheel and may cause chain breakage and/or damage to hoist unit. To ensure safe and efficient operation, the chain links must be checked for their pitch (inside length), inside width and outside width monthly according to following table.

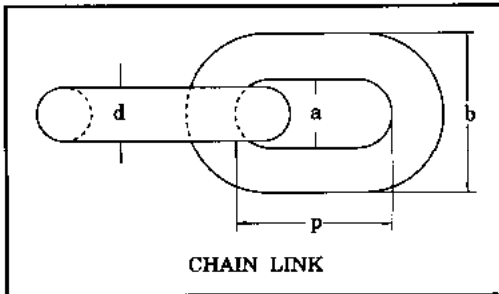

Dia-Meter (mm) (d)	Load (t)	Inside Length (mm) (p)	Inside Width (mm) (a)	Outside Width (mm) (b)
4.0	0.25, 0.5	12.0	14.0	5.0
6.3	0.5, 1	19.1	7.6	21.4
7.1	1, 2	20.2	8.9	23.6

Table 6-2-a



WARNING

Always use the hoist manufacture's recommended parts when repairing a hoist.

Measuring

- (1) The chain gauge is useful and convenience for measuring.
- (2) Please use a chain gauge to measure the chain pitch and diameter, per illustrations (1) and (2).
- (3) Every chain ring must be measured, and the chain must be replaced when one of chain ring is wear or stretch.
- (4) It will be a cutting-out possibility if you use a chain fall either wear or stretch during operation.
- (5) Do not replace a chain fall by yourself and do please contact specific either service centers or contractors to help you out.
- (6) The chain fall must be replaced whole instead of in part.
- (7) The load sheave, regulator, and regulator plate wheel must be replaced the same time as you do a chain replacement.

Note : Chain must be in perfect condition without any defects.

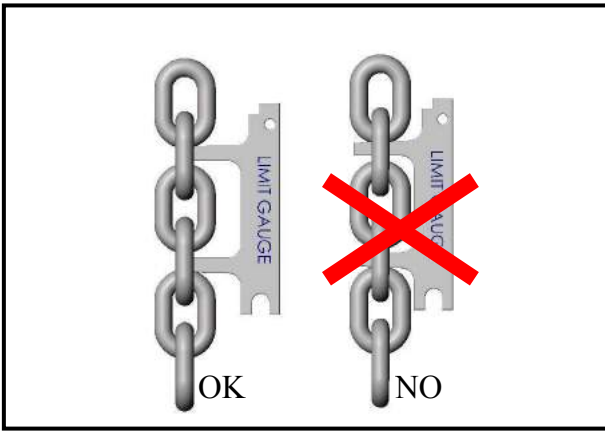

Illustration (1) Chain pitch measure

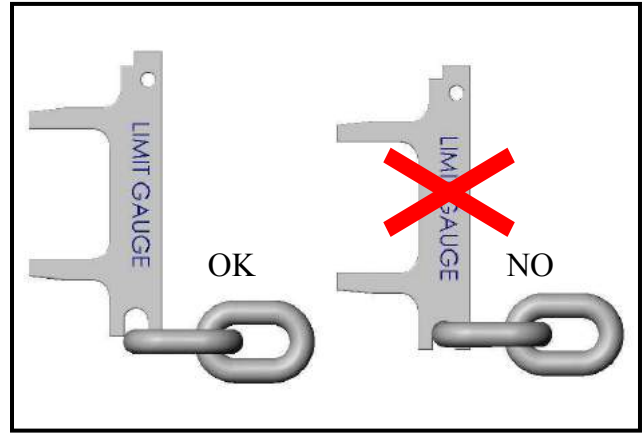
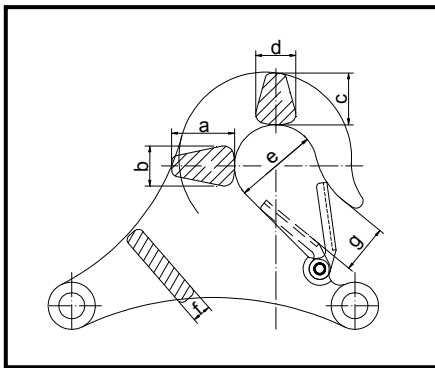
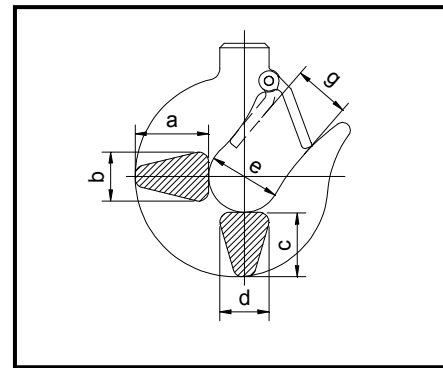

Illustration (2) Diameter measure

(b) Check hook with care. If hook shows cracks, deformation or excessive wear, it should be replaced.



Top Hook



Bottom Hook

Table 6-2-b

Model	Capacity	Hook	Approximate Dimensions (mm)						
			a	b	c	d	e	f	g
PEH-025	250kg	T	26.7	17.0	22.0	17.0	35.0	8.0	20.7
		B	20.0	12.0	20.0	12.0	36.0		27.2
PEH-050-2	500kg	T	26.7	17.0	22.0	17.0	35.0	8.0	20.7
		B	28.0	18.0	23.0	18.0	35.0		25.6
PEH-050	500kg	T	33.0	22.0	29.0	22.0	25.2	12.0	28.8
		B	33.0	22.0	29.0	22.0	32.0		29.5
PEH-100-2	1 ton	T	33.0	22.0	29.0	22.0	32.0	12.0	28.0
		B	33.0	22.0	29.0	22.0	32.0		28.0
PEH-100	1 ton	T	38.0	28.0	33.0	28.0	46.0	12.0	35.8
		B	33.0	22.0	29.0	22.0	32.0		28.0
PEH-200	2 ton	T	38.0	28.0	33.0	28.0	46.0	12.0	35.8
		B	40.0	26.5	39.0	26.5	40.0		36.0

Top Hook=T Bottom Hook=B

3. Annual inspection



WARNING

Your dealer should be asked to perform this inspection.

- (a) Check gearing for any excessive wears or damage.
- (b) Replace gearbox lubricant completely (**PEH-025 & PEH-050-2 / 400C.C., PEH-050 & PEH-100-2 / 800C.C., PEH-100 & PEH-200 / 1400C.C.**) as following table for your reference.

※Table of recommended oils according to DIN 51354

ISO-VGDIN 51519 viscosity At 40°C mm ² /s (cST)	Approximate viscosity of the VG Categories 50°C mm ² /s (cST)	ARAL	BP	ESSO	MOBIL OIL
VG460	251	Aral Degol BG 460-BMB 460	BP Energol GR-XP 460	Spartan EP-460	Mobilgear 634

ISO-VGDIN 51519 Viscosity at 40°C mm ² /s (cST)	Approximate viscosity of the VG Categories 50°C mm ² /s (cST)	SHELL	TEXACO	I..P.	AGIP
VG460	251	Omala oil 460	Meropa 460	Mellana 460	Blasia 460

The permissible tolerance for each VG category is $\pm 10\%$ of the tabulated values.

- (a) Check brake lining for any wear or damage.
- (b) On completion of above checks, lift a load several times to ensure good performance of the hoist before starting duty operation.

7. TROUBLESHOOTING

7.1 Wiring Diagrams

- (1) A20107A for connection of motor leads 20
- (2) A20101D for trolley 21

The above listed wiring diagram for reference only.

The end user should refer to the wiring diagram stuck to the inside cover of the electric housing.

Our electric specifications apply to the following -

- (a) 3-Phase
- (b) 50Hz

Voltage	Voltage
Hertz	
50Hz	415V

Table 7-1

KM1: Magnetic Contactor For "Emergency Stop"
 KM2&KM3: Magnetic Contactor For "Hoisting"
 KM4: Magnetic Contactor For "Fast"(Hoisting)
 TC: Control Transformer
 TR1&TR2: Temperature Switch
 LS: Limit Switch For "Hoisting"

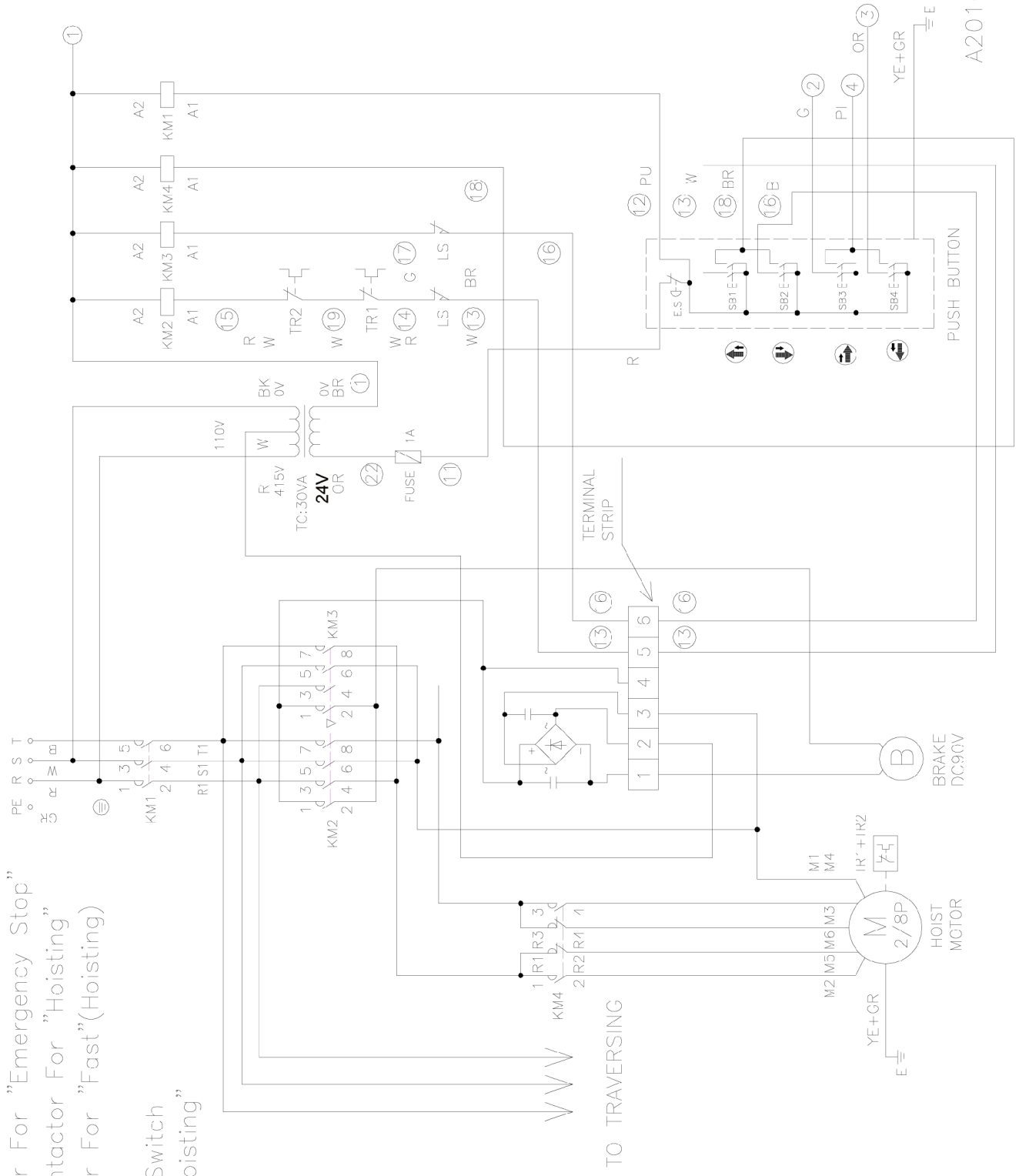

CCLOR CODE:
 R-RED
 W-WHITE
 B-BLACK
 GR-GREEN
 PU-PURPLE
 C-GRAY
 OR-ORANGE
 PI-PINK
 YE-YELLOW
 BL-BLUE
 BR-BROWN

COLOR CODE:
 R-RED
 W-WHITE
 B-BLACK
 GR-GREEN
 PU-PURPLE
 G-GREY
 OR-ORANGE
 PI-PINK
 YE-YELLOW

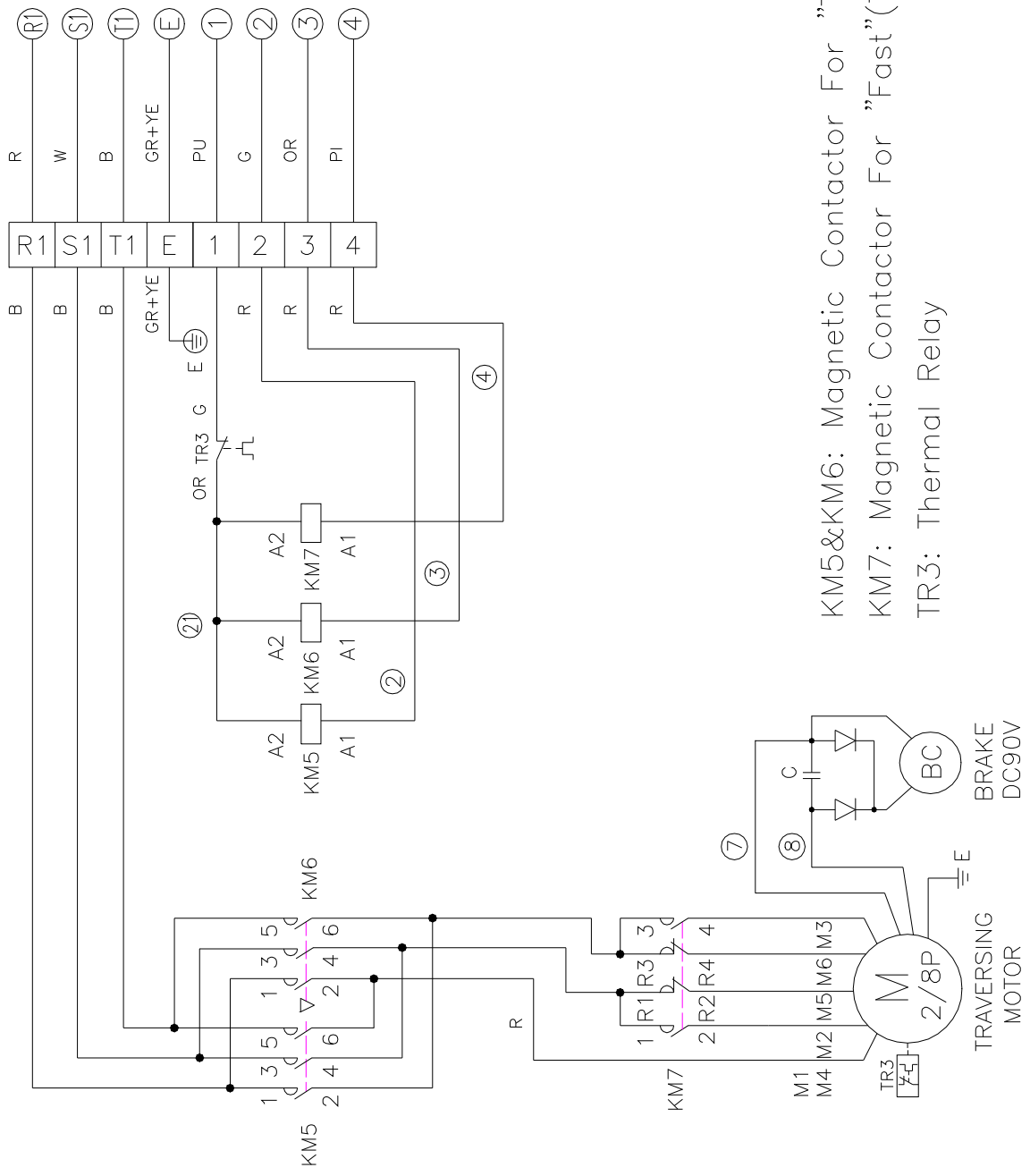

KM5&KM6: Magnetic Contactor For "Traversing"
 KM7: Magnetic Contactor For "Fast"(Traversing)
 TR3: Thermal Relay

A20101D

7.2 Troubleshooting and Remedial Action

SITUATION	CAUSE	REMEDY
Hoist will not operate	<p>(1) Broken/disconnected power or control circuit wire.</p> <p>(2) Low supply voltage</p> <p>(3) Motor hums but does not rotate</p> <p>(4) Emergency stop button release pushed</p> <p>(5) Faulty contactor</p>	<p>Locate and repair/reconnect</p> <p>Check if 10% reduction in voltage, have main supply checked</p> <p>Check phases to motor-insulate and repair</p> <p>Check the cause as necessary</p> <p>Operate manually if hoist runs then control circuit/coil is faulty-locate fault and repair. If hoist does not run then check main supply. If input supply is correct but there is a faulty output supply then replace the contactor</p>
Hoist will not stop	Welded contacts in contactor	Replace contactor
Brake slips	Abrasion of motor brake	Replace
Hoist runs but does not lift	(1) Clutch slipping	Contact your authorized Pacific Hoist dealer – this adjustment needs to be carried out on a test rig
Abnormal sound on load chain/chain sprocket (2 falls)	<p>(1) Chain dry</p> <p>(2) Worn chain sprocket (2 falls)</p>	<p>Lubricate</p> <p>Replace load chain and chain sprocket (2 falls)</p>
Electric shock	<p>(1) Poor earth connection</p> <p>(2) Accumulated foreign matter/ moisture on electrical parts</p>	<p>Provide correct earth connection</p> <p>Remove foreign matter/dry electrical parts</p>
Oil leak	<p>(1) No oil plug</p> <p>(2) Loose fitting of oil plug</p> <p>(3) No plug packing</p> <p>(4) Worn or deteriorated oil packing</p>	<p>Attach the normal oil plug</p> <p>Fasten the plug tightly</p> <p>Attach normal packing</p> <p>Attach the new packing</p>

8. DRAWINGS AND PARTS LISTS

(1) MOTOR ASSEMBLY & HOUSING B.O.M	24
(2) HOOK ASSEMBLY B.O.M	26
(3) LOAD CHAIN ASSEMBLY B.O.M	28
(4) GEARBOX ASSEMBLY B.O.M	29
(5) ELECTRIC ASSEMBLY B.O.M	31
(6) TROLLEY ASSEMBLY B.O.M	33
(7) TROLLEY MOTOR ASSEMBLY B.O.M	35

MOTOR EXPLOSION & HOUSING

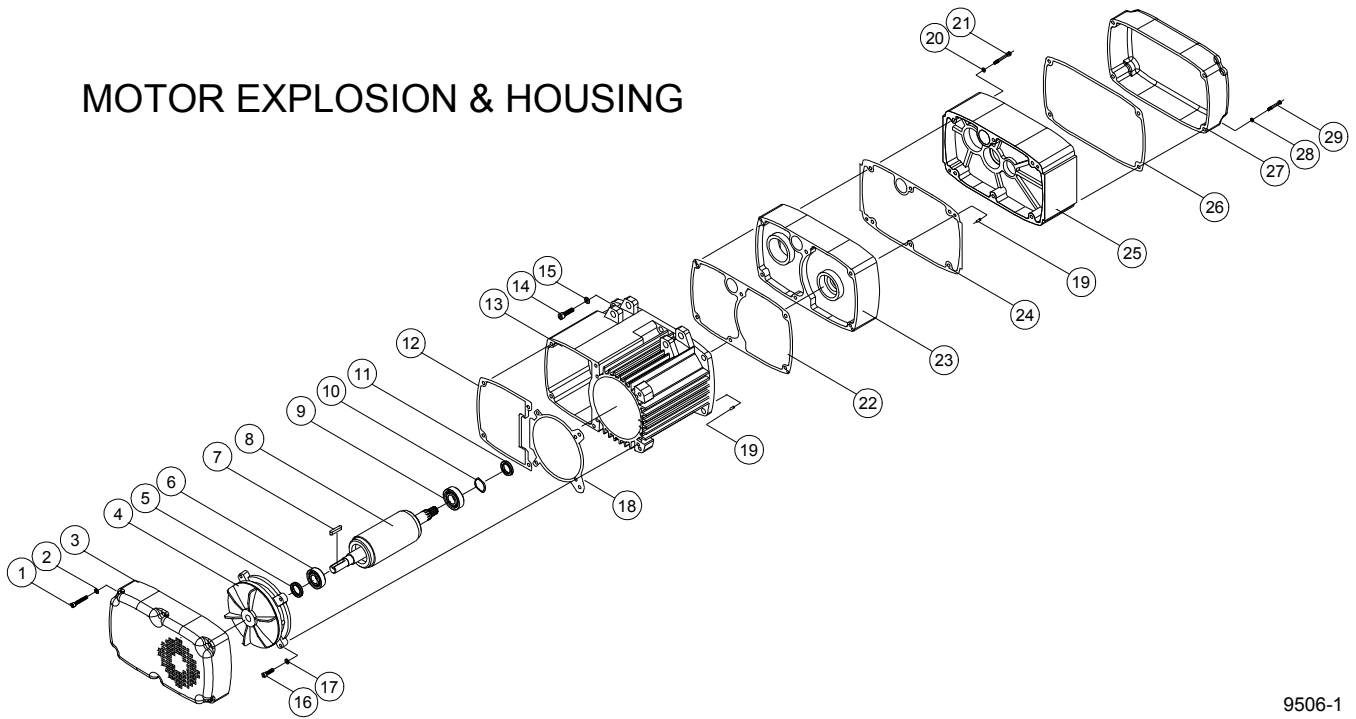

9506-1

MOTOR ASSEMBLY & HOUSING

NO.	PARTS CODE	DESCRIPTION	Q'TY REQ'D EACH UNIT		
			025 / 050-2	050 / 100-2	100 / 200
1	408330	Hex. Recess Bolt <M5x0.8x45L>	6		
	408331	Hex. Recess Bolt <M5x0.8x50L>		6	
	408337	Hex. Recess Bolt <M6x1.0x60L>			6
2	400854	Spring Washer <M5>	6	6	
	400855	Spring Washer <M6>			6
3	301410I	End Cover	1		
	208809			1	
	301419				1
4	100448	Brake Ass'y	1		
	100449			1	
	100504				1
5	400932	Oil Seal <ø15xø30x7t>	1		
	404413	Oil Seal <ø17xø35x8t>		1	
	400186	Oil Seal <ø20xø35x8t>			1
6	400111	Bearing <6202 ZZ>	1		
	400732	Bearing <6203 ZZ>		1	
	400130	Bearing <6204 ZZ>			1
7	400947	Key <t5x5x25L>	1	1	
	400960	Key <t5x5x30L>			1
8	100315	Motor Rotor	1		
	100316			1	
	100311				1
9	400732	Bearing <6203 ZZ>	1		
	400130	Bearing <6204 ZZ>		1	
	400143	Bearing <6205 ZZ>			1
10	400577	Wave Washer <6204>		1	
	407553	Wave Washer <6205>			1
11	400181	Oil Seal <ø17xø28x6t>	1		
	400186	Oil Seal <ø20xø35x8t>		1	
	400891	Oil Seal <ø25xø45x8t>			1
12	402562	End Cover Gasket	1		
	402563			1	
	402564				1

MOTOR ASSEMBLY & HOUSING

NO.	PARTS CODE	DESCRIPTION	Q'TY REQ'D EACH UNIT		
			025 / 050-2	050 / 100-2	100 / 200
13	106453	Motor Stator Ass'y	1		
	106468			1	
	106455				1
14	408342	Hex. Recess Bolt <M8x1.25x20L>	6		
	408346	Hex. Recess Bolt <M8x1.25x35L>		6	
	408339	Hex. Recess Bolt <M8x1.25x25L>			6
15	400856	Spring Washer <M8>	6	6	6
16	400417	Hex. Recess Bolt <M5x0.8x20L>	4		
	405020	Hex. Recess Bolt <M5x0.8x25L>		4	
	400008	Hex. Recess Bolt <M6x1.0x25L>			4
17	400093	Spring Washer <M5>	4	4	
	400094	Spring Washer <M6>			4
18	402565	Brake Gasket	1		
	402566			1	
	402567				1
19	400615	Pin	4	4	4
20	400094	Spring Washer <M6>	6	6	6
21	405022	Hex. Recess Bolt <M6x1.0x40L>	6		
	405023	Hex. Recess Bolt <M6x1.0x45L>		6	
	400010	Hex. Recess Bolt <M6x1.0x55L>			6
22	402558	Motor Gasket		1	
23	200960I	Gearbox	1		
	208810			1	
	200976				1
24	402597	Gearbox Gasket	1		
	402557			1	
	402598				1
25	200959I	Gearbox Cover	1		
	208811			1	
	200977				1
26	402568	Electric Cover Gasket	1		
	402569			1	
	402570				1
27	300834I	Electric Cover	1		
	300384			1	
	300839				1
28	400854	Spring Washer <M5>	4	6	
	400855	Spring Washer <M6>			6
29	408330	Hex. Recess Bolt <M5x0.8x45L>	4	6	
	408333	Hex. Recess Bolt <M6x1.0x25L>			6

HOOK EXPLOSION

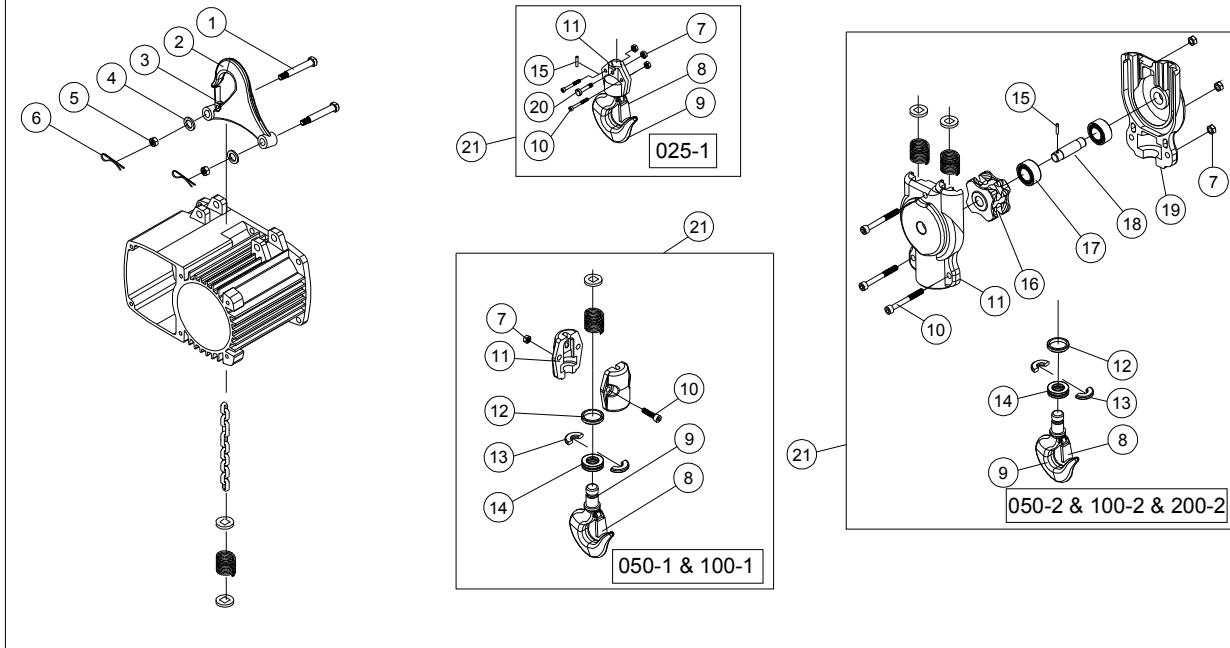

HOOK ASSEMBLY

NO.	PARTS CODE	DESCRIPTION	Q'TY REQ'D EACH UNIT					
			025	050-2	050	100-2	100	200
1	201368	Lock Bolt <ø10.5x64L>	2	2				
	201310	Lock Bolt <ø14x83L>			2	2	2	2
2	200016I	Top Hook Ass'y	1	1				
	208812				1	1		
	200018						1	1
3	400300	Safety Latch Ass'y	1	1	1	1	1	1
4	400096	Spring Washer <M10>	2	2				
	400097	Spring Washer <M12>			2	2	2	2
5	400082	Nut <M10x1.5>	2	2				
	400084	Nut <M12x1.75>			2	2	2	2
6	400610	Cotter Pin <ø3x30L>	2	2	2	2	2	2
7	400646	Nylon Nut<M5>	3	3				
	400088	Nylon Nut <M8x1.25>			2	3		3
	400087	Nylon Nut <M6x1.0>					4	
8	200480	Safety Latch Ass'y	1					
	400300			1	1	1	1	
	400358							1
9	201372I	Bottom Hook Ass'y	1					
	200367			1				
	200015I				1			
	200001I					1		
	200047						1	
	200002							1
10	408329	Hex. Recess Bolt <M5x0.8x20L>	2	3				
	408339	Hex. Recess Bolt <M8x1.25x25L>			2		2	
	408334	Hex. Recess Bolt <M6x1.0x30L>				3		
	408345	Hex. Recess Bolt <M8x1.25x30L>						3

HOOK ASSEMBLY

NO.	PARTS CODE	DESCRIPTION	Q'TY REQ'D EACH UNIT					
			025	050-2	050	100-2	100	200
11	201371I	Bottom Block Cover	2					
	200102I				2			
	207073						2	
	207069	Bottom Block Cover A		1				
	200103I				1			
	207074							1
	207071			1				
	200103I	Bottom Block Cover B				1		
207075							1	
12	200221	End Spacer		1				
	200131				1	1	1	
	200132							1
13	200212	Half Spacer		2				
	200127				2	2	2	
	200128							2
14	400830	Thrust Bearing <51102>	1					
	408057	Thrust Bearing <51103>		1				
	400157	Thrust Bearing <2904>			1	1	1	
	400158	Thrust Bearing <2905>						1
15	400210	Spring Pin <ø8x24L>	1					
	400295	Spring Pin <ø3x10L>		1				
	400211	Spring Pin <ø3x14L>				1		
	400212	Spring Pin <ø5x16L>						1
16	200361	Sprocket		1				
	200954					1		
	200108							1
17	408058	Needle Bearing <HK1412>		2				
	408055	Needle Bearing <HK1612>				2		
	400171	Needle Bearing <HK 25/26>						1
18	200322	Sprocket Axle		1				
	200953					1		
	200114							1
19	207071	Bottom Block Cover B		1				
	200104I					1		
	207075							1
20	200445	Bottom Hook Pin <ø10x25.5L>	1					
21	201370	Bottom Hook Cover Ass'y	1					
	200466			1				
	200020				1			
	200465					1		
	201377						1	
	200464							1

LOAD CHAIN EXPLOSION

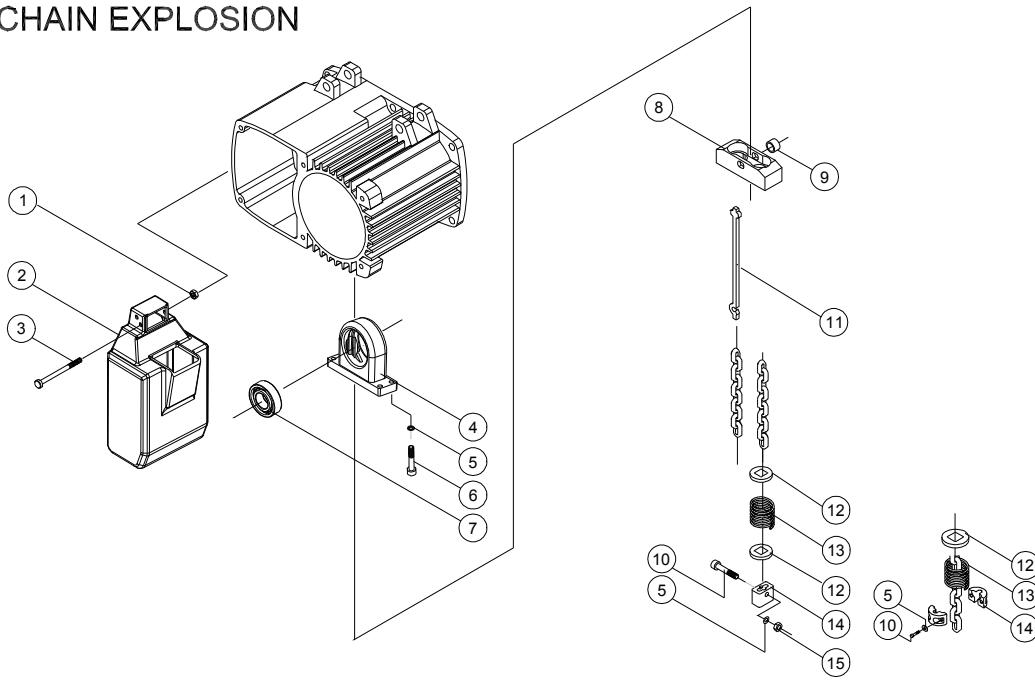

9506-3B

LOAD CHAIN ASSEMBLY

NO.	PARTS CODE	DESCRIPTION	Q'TY REQ'D EACH UNIT		
			025 / 050-2	050 / 100-2	100 / 200
1	400646	Nylon Nut <M5>	2	2	
	400087	Nylon Nut <M6>			2
2	208813	Chain Bucket <ø4.0-1#>	1		
	201386	Chain Bucket <ø6.3-2#>		1	
	208807	Chain Bucket <ø7.1-3#>			1
3	408343	Hex. Recess Bolt <M5x0.8x60L>	2	2	
	408338	Hex. Recess Bolt <M6x1.0x65L>			2
4	200958	Chain Regulator	1		
	200979			1	
	200955				1
5	400093	Spring Washer <M5>	5		
	400094	Spring Washer <M6>		6	6
6	400003	Hex. Recess Bolt <M5x0.8x16L>	4		
	400006	Hex. Recess Bolt <M6x1.0x16L>		4	4
7	400732	Bearing <6203 ZZ>	1		
	400108	Bearing <6006 ZZ>		1	
	400134	Bearing <6008 ZZ>			1
8	201351	Collision Block	1		
	201384			1	
	201375				1
9	201388	Spacer <ø15xø10.5x11.5L>		1	
10	400417	Hex. Recess Bolt <M5x0.8x20L>	1		
	400007	Hex. Recess Bolt <M6x1.0x20L>		2	2
11	400512	Substitute Chain <ø4.0x12>	1		
	400513	Substitute Chain <ø6.3x19.1>		1	
	400511	Substitute Chain <ø7.1x20.2>			1
12	200442	Limit Stopper Ass'y	4	6	
	200310				2
13	408485	Spring	2	3	
	408502				2
14	200441	Chain Stopper	1		
	200200			2	2
15	400646	Nylon Nut <M5>	1		

GEAR BOX EXPLOSION

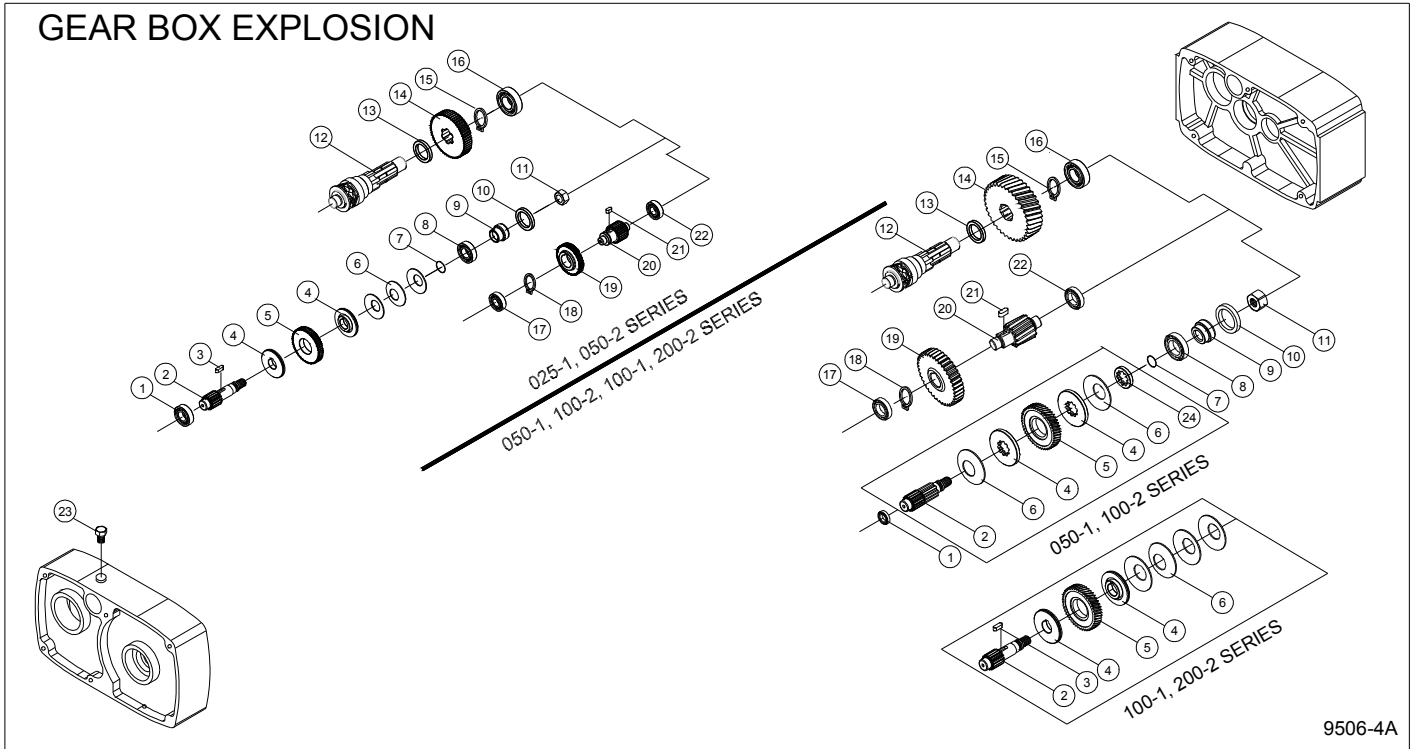

9506-4A

GEAR BOX ASSEMBLY

NO.	PARTS CODE	DESCRIPTION	Q'TY REQ'D EACH UNIT		
			025 / 050-2	050 / 100-2	100 / 200
1	407869	Bearing <6002 ZZ>	1		
	407839	Bearing <6000 ZZ>		1	
	400694	Bearing <6203 Z>			1
2	201301	5th Gear <M1.25x18Tx91.5L>(50Hz)	1		
	200942	3rd Gear <M2x10Tx90.5L>		1	
	201347	3rd Gear <M2x10Tx119.5L>			1
3	405933	Key <t5x5x15L>	1		
	400960	Key <t5x5x30L>			1
4	201362	Brake Disc	2		
	200948			2	
	201345				2
5	201359	4th Gear <M1x55Tx9L>	1		
	200940	2nd Gear Copper Bushing Ass'y		1	
	201348	2nd Gear <M1.5x46Tx15L>			1
6	407324	Disc Spring <ø34xø16.3x2.0t>	3		
	400579	Disc Spring <ø50xø22.4x2.0t>		2	
	408403	Disc Spring <ø40xø16.3x2.0t>			4
7	404343	O-Ring <ø9xø15x3>	1	1	1
8	407868	Bearing <6904 ZZ>	1		
	407858	Bearing <6905 ZZ>		1	1
9	201363	Oil Seal Bushing <ø25x21L>	1		
	200937	Oil Seal Bushing <ø30xø15x18L>		1	
	201343	Oil Seal Bushing <ø30x23L>			1
10	400943	Oil Seal <ø25xø35x5t>	1		
	404411	Oil Seal <ø30xø40x6t>		1	1
11	404552	Nylon Nut <M12x1.25>	1		
	400090	Nylon Nut <M12x1.25>		1	1
12	201364	Load Sheave	1		
	201383			1	
	201376				1

GEAR BOX ASSEMBLY

NO.	PARTS CODE	DESCRIPTION	Q'TY REQ'D EACH UNIT		
			025 / 050-2	050 / 100-2	100 / 200
13	400893	Oil Seal <ø30xø42x8t>	1		
	400938	Oil Seal <ø40xø62x12t>		1	
	404401	Oil Seal <ø40xø72x12t>			1
14	201302	6th Gear <M1.25x53Tx16L>(50Hz)	1		
	200945	6th Gear <M2.25x36Tx32L>(50Hz)		1	
	201349	6th Gear <M2.5x45Tx30L>(50Hz)			1
15	400192	Retaining Ring <S-25>	1		
	404161	Retaining Ring <S-38>			1
16	407840	Bearing <6004 ZZ>	1		
	400130	Bearing <6204 ZZ>		1	
	400803	Bearing <6205 Z>			1
17	407867	Bearing <6001 ZZ>	1		
	400111	Bearing <6202 ZZ>		1	
	400695	Bearing<6204 Z>			1
18	400191	Retaining Ring <S-20>	1		
	400192	Retaining Ring <S-25>			1
19	201357	2nd Gear <M0.8x60Tx12L>	1		
	200943	4th Gear <M2x38Tx17L>		1	
	201344	4th Gear <M2x46Tx22L>			1
20	201358	3rd Gear <M1x26Tx56.1L>	1		
	200944	5th Gear <M2.25x12Tx73.5L>(50Hz)		1	
	201342	5th Gear <M2.5x12Tx95L>(50Hz)			1
	201305	5th Gear <M2.25x12Tx95L>(60Hz)			1
21	400961	Key <t6x6x10L>	1		
	400963	Key <t6x6x15L>		1	
	400974	Key <t8x8x20L>			1
22	407867	Bearing <6001 ZZ>	1		
	400111	Bearing <6202 ZZ>		1	
	400787	Bearing <6205 Z>			1
23	408388	Ventilated Lubricant Drain Bolt	2	2	2
24	200938	Disc Spring Bushing		1	

ELECTRIC EXPLOSION

31

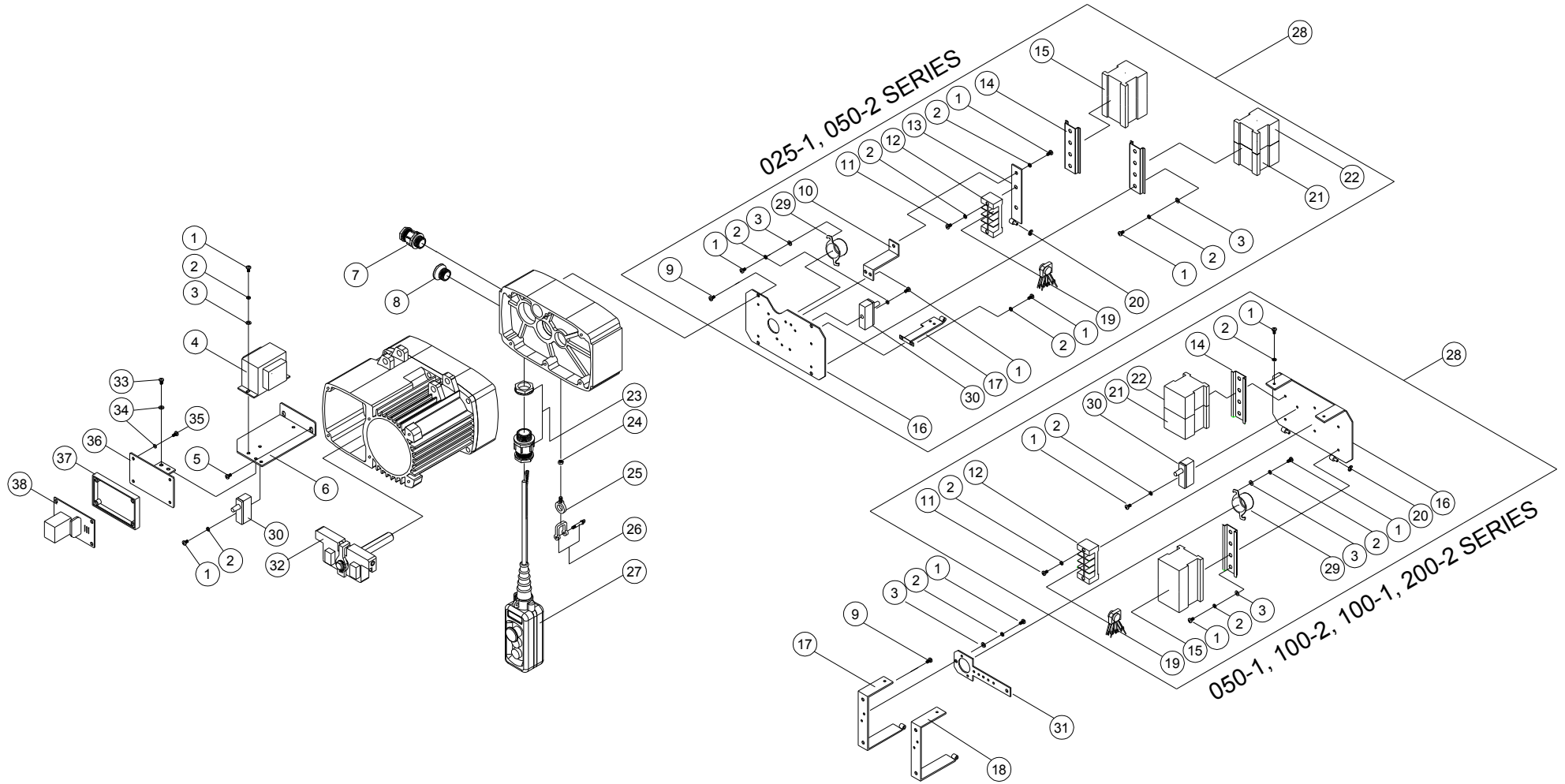

ELECTRIC ASSEMBLY

NO.	PARTS CODE	DESCRIPTION	Q'TY REQ'D EACH UNIT		
			025 / 050-2	050 / 100-2	100 / 200
1	400048	Cross Headed Screw <M4x0.7x6L>	12	19	19
2	400092	Spring Washer <M4>	18	25	25
3	400661	Flat Washer <M4>	8	10	10
4	303757	Transformer	1	1	1
5	408361	Cross Headed Screw <M5x0.8x8L>	2	2	2
6	300625	Transformer Bracket	1		
	300629			1	1
7	400222	Cable Gland <M20>	1	2	2
8	408436	Rotation Plug	1	1	1
9	408360	Cross Headed Screw <M5x0.8x10L>	4	4	4
10	201391	Terminal Plate A	1		
11	400051	Cross Headed Screw <M4x0.7x12L>	2	2	2
12	300646	Terminal Block	1		
	300228			1	1
13	201392	Bracket Ass'y	1		
14	300079	Contactora Rail	2	2	2
15	300045	Magnetic Contactora <4A>	1	1	1
16	201394	Electric Bracket Ass'y	1		
	300382			1	1
17	201393	Bracket Located Seat	1		
	300383			1	1
18	300261	Bracket Located Seat B		1	1
19	300143	Rectifier	1	1	1
20	404252	E-Retaining Ring<ø5>	1	2	2
21	300046	Magnetic Contactora <2A2B>	1	1	1
22	300044	Magnetic Contactora <3A1b>	1	1	1
23	400941	Cable Gland <M25>	1	1	1
24	400087	Nylon Nut <M6>	1	1	1
25	404803	Eye Bolt <M6x1.0>	1	1	1
26	400595	Shackle <3/16">	1	1	1
27	303901	Push Button Switch	1	1	1
28	307043	Electric Ass'y	1		
	307044			1	1
29	208836	Cover	1		
	208838			1	1
30	300589	Fuse Ass'y	2	2	2
31	208837	Cover Plate		1	1
32	302603	Upper & Lower Limit Switch	1		
	302635			1	
	302604				1
33	400049	Cross Headed Screw <M4x0.7x8L>		2	2
34	400092	Spring Washer <M4>		6	6
35	400052	Cross Headed Screw <M4x0.7x15L>		4	4
36	300675	N.P.P Holding Plate		1	1
37	300363	N.P.P/E.O Box		1	1
38	300185	Negative Phase Protector(N.P.P)		1	1

TROLLEY EXPLOSION

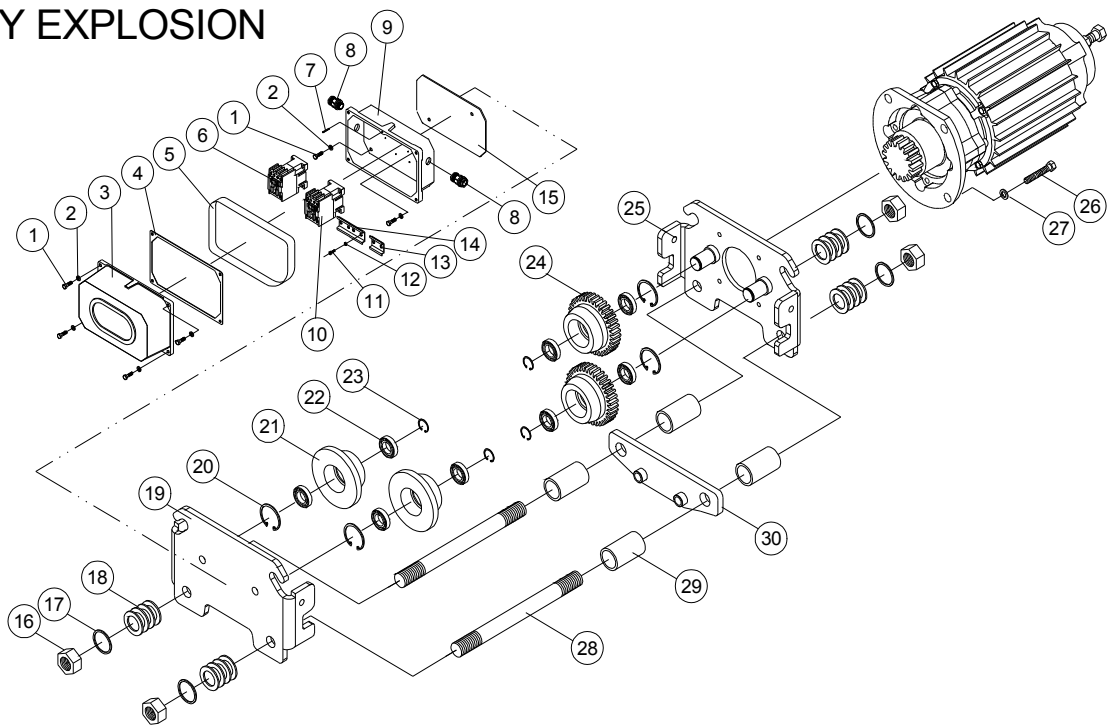

9506-6

TROLLEY ASSEMBLY

NO.	PARTS CODE	DESCRIPTION	Q'TY REQ'D EACH UNIT				
			PET-050-2 PET-055-2	PET-050 PET-055	PET-100-2 PET-105-2	PET-100 PET-105	PET-200 PET-205
1	400006	Hex. Recess Bolt <M6x1.0x16L>			6		
2	400094	Spring Washer <M6>			6		
3	300348I	Electric Housing Cover			1		
4	402515	Gasket #15			1		
5	400266	Rubber Band			1		
6	301102	Magnetic Contactor <3Alab>			1		
7	400211	Spring Pin <ø3x14L>			1		
8	400222	Cable Gland <M20>			3		
9	300303I	Electric Housing			1		
10	300036	Magnetic Contactor <2A2B>			1		
11	400052	Cross Headed Screw <M4x0.7x15L>			8		
12	400092	Spring Washer <M4>			8		
13	300078	Contactor Rail <1PC>			1		
14	300079	Contactor Rail <2PC>			1		
15	402516	Gasket #16			1		
16	400070	Hex. Nut <7/8"x9UNC>	4	4	4	4	
	400071	Hex. Nut <1"x8UNC>					4
17	400102	Spring Washer <7/8">	4	4	4	4	
	400103	Spring Washer <1">					4
18	203221	Spacer Washer <ø40xø24x1/8">	32	32	32	32	
	203222	Spacer Washer <ø46xø27x1/8">					32
19	210311	Electric Frame Ass'y	1	1	1	1	
	210318						1
20	400922	Retaining Ring <R-40>	4	4	4	4	
21	203128	Plain Wheel <ø88x28L>	2	2	2	2	
	203132	Plain Wheel <ø119x49L>					2
22	407850	Bearing <6203 ZZ>	4	4	4	4	
	407715	Bearing <6205 ZZ>					8

TROLLEY ASSEMBLY

NO.	PARTS CODE	DESCRIPTION	Q'TY REQ'D EACH UNIT				
			PET-050-2 PET-055-2	PET-050 PET-055	PET-100-2 PET-105-2	PET-100 PET-105	PET-200 PET-205
23	404184	Retaining Ring <S-17>	4	4	4	4	
	400192	Retaining Ring <S-25>					4
24	203110	Gear Wheel <M2x46Tx33L>	2	2	2	2	
	210323	Gear Wheel <ø130x54L>					2
25	210312	Motor Frame Ass'y	1	1	1	1	
	210317						1
26	408364	Hex. Headed Bolt <M10x1.5x20L>	4	4	4	4	
	408358	Hex. Headed Bolt <M10x1.5x25L>					4
27	400857	Spring Washer <M10>	4				
28	408366	Stay Bolt <7/8"x9UNCx265L>	2	2	2	2	
	408369	Stay Bolt <1"x8UNCx300L>					2
29	203151	Position Tube <ø34xø24x56L>	4	4	4	4	
	203152	Position Tube <ø38xø28x69L>					4
30	210324	Load Bracket	1				
	210314			1	1		
	203439					1	
	210321						1

TROLLEY MOTOR EXPLOSION

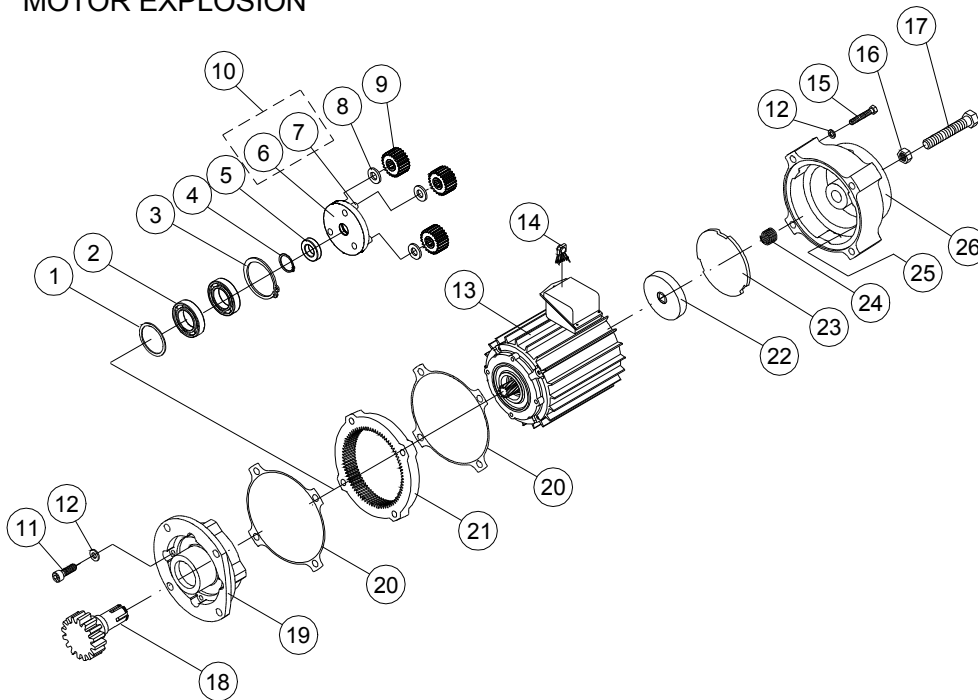

9506-7

TROLLEY MOTOR ASSEMBLY

NO.	PARTS CODE	DESCRIPTION	Q'TY REQ'D EACH UNIT				
			PET-050-2 PET-055-2	PET-050 PET-055	PET-100-2 PET-105-2	PET-100 PET-105	PET-200 PET-205
1	400182	Oil Seal <ø25xø40x6t>			1		
2	400695	Bearing <6204 Z>			2		
3	400198	Retaining Ring <R-47>			1		
4	400191	Retaining Ring <S-20>			1		
5	200347	Axle Sleeve			1		
6	200328	Reducing Gear Frame			1		
7	200344	Planetary Gear Shaft			3		
8	400669	Flat Washer <ø21xø11x2t>			3		
9	200337	Planetary Gear			3		
10	200324	Reducing Gear Frame Ass'y			1		
11	405017	Hex. Headed Bolt <M6x1x60L>			4		
12	400855	Spring Washer <M6>			8		
13	106447	Motor Ass'y <0.12/0.03kW>	1	1			
	106448	Motor Ass'y <0.18/0.04kW>			1	1	
	106469	Motor Ass'y <0.37/0.09kW>					1
	106452	Motor Ass'y <0.12kW>	1 (PET-050-2)	1 (PET-050)			
	106432	Motor Ass'y <0.18kW>			1 (PET-100-2)	1 (PET-100)	
	106435	Motor Ass'y <0.37kW>					1 (PET-200)
14	300144	Rectifier			1		
15	408357	Hex. Headed Bolt <M6x1.0x20L>			4		
16	400084	Nut <M12x1.75>			1		
17	400030	Hex. Headed Bolt <M12x1.75x30L>			1		
18	201772	Transmission Shaft With Pinion	1	1	1	1	
	210329						1
19	200320I	Gear Box			1		
20	402513	Gear Box Gasket			2		
21	200334I	Inner Teeth Gear Sleeve			1		
22	100480	Brake Lining Ass'y			1		
23	100407	Brake Disc			1		
24	400239	Brake Spring			1		
25	400258	Brake Coil			1		
26	100396I	Brake Drum			1		



DECLARATION OF CONFORMITY



CHENG DAY MACHINERY WORKS CO., LTD.
173 WEN CHIU ROAD, TA CHIA CHEN,
TAICHUNG HSIEN, TAIWAN R.O.C.

We declare under our sole responsibility that the products:

Electric chain hoist: PEH025 & PEH-050-2
PEH050 & PEH-100-2
PEH100 & PEH200

Electric Motorized: PET-050(055), PET-100(105), PET-200(205)

Working Load Limit: from 250KGS to 2000KGS.

To which this declaration relates is in conformity with the following Machinery Directive and Standard:

- Machinery Directive 98 / 37 / EC.
- Low Voltage Directive 73 / 23 / EEC.
- EMC Directive 89 / 336 / EEC.
- ISO 12100-1 (E) (Basic terminology, methodology)
- ISO 12100-2 (E) (Technical principles)
- EN 418 (Emergency stop equipment, functional aspects)
- EN 60204-1 (Electrical equipment of machines)
- FEM 9.511 (Classification of mechanisms)
- FEM 9.681 (Selection of travel motors)
- FEM 9.682 (Selection of lifting motors)
- FEM 1.001 (Rules for the design of hoisting appliances)

We will keep the technical documents listed below at our Head Office Factory above mentioned for any concerned national authorities inspection purposes.

- Operation manual for the products.
- Overall drawings of the products.
- Description of methods adopted to meet the Machinery Directive.
- Other technical materials.

We declare moreover as required by the annex IV of Machine Directive 98 / 37 / EC:

-The Marking is placed on the machine

Hoist type / Trolley:.....

Capacity (Ton):.....Serial No:.....

CHENG DAY MACHINERY WORKS CO., LTD.

C.F. HUANG

C. F. HUANG
MANAGER
QUALITY ASSURANCE DEPT.

DATE: