

## Challenger ATOM Mini Lever Block

Challenger's new innovative full body aluminium construction mini lever hoist, is an extremely light weight and compact unit. Offering numerous use application across a variety of industries, this is the perfect lever block for every tool box.



## Features:

- All Challenger models are manufactured to comply with AS1418.2
- Light weight alloy body
- Electrostatic matte black coating (suitable for entertainment industry & automotive industry)
- Unique design developed to optimize lift performance
- 2 year warranty; best warranty in market
- G80 Zinc plated chain
- Protective belt pouch included
- 1m Height of Lift

The information shown is to be used as a guide only. Specifications are subject to change without notice. All materials handling or lifting jobs should be assessed individually. Pacific Hoists products are NOT to be used for lifting or lowering persons.

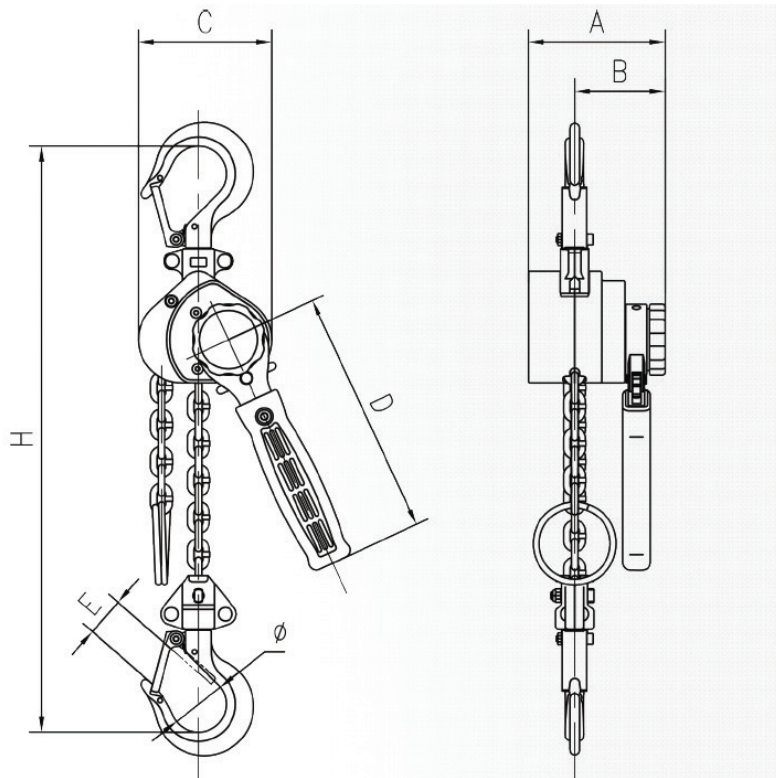

## Specifications

| Model                            | CML025 |     |
|----------------------------------|--------|-----|
| Rated Capacity (kg)              | 250    |     |
| Lifting Height (m)               | 1      |     |
| Chain falls                      | 1      |     |
| Load Chain Grade 80 (mm)         | 3 x 9  |     |
| Net Weight (kg)                  | 1.0    |     |
| Min. distance between hooks (mm) | H      | 220 |
| Length of Lever Handle (mm)      | D      | 150 |
| Overall Dimension (mm)           | A      | 81  |
|                                  | C      | 53  |
|                                  | Ø      | 32  |
|                                  | E      | 21  |

### Sydney - Head Office

24 Foundry Road  
Seven Hills, NSW 2147  
Australia

☎ +61 (0)2 8825 6900

☎ +61 (0)2 8825 6999

### Western Australia

8 Monash Gate  
Jandakot, WA 6164  
Australia

☎ +61 (0)8 6253 1000

☎ +61 (0)8 9458 9840

### Auckland NZ

11 Druces Road  
Wiri, Auckland 2104  
New Zealand

☎ +64 (0)9 263 5566

☎ +64 (0)9 263 5567

