

Pacific Electric Chain Hoist

U-MEGA Series

OPERATION MANUAL & PARTS LIST

Model

PEH050	PEH050NH
PEH100	PEH100NH
PEH200-2	PEH200-2NH
PEH200-1	PEH200-1NH
PEH300-2	PEH300-2NH
PEH500-2	PEH500-2NH



SAFETY-IMPORTANT

The use of any hoist and trolley presents some risk of personal injury or property damage.

That risk is greatly increased if proper instructions and warnings are not followed. Before using this hoist, each user should become thoroughly familiar with all warnings, instructions and recommendations herein.



THIS SYMBOL POINTS OUT IMPORTANT SAFETY INSTRUCTIONS WHICH IF NOT FOLLOWED COULD ENDANGER THE PERSONAL SAFETY AND/OR PROPERTY OF YOURSELF AND OTHERS.

READ AND FOLLOW ALL INSTRUCTIONS IN THIS MANUAL AND ANY PROVIDED WITH THE EQUIPMENT BEFORE ATTEMPTING TO OPERATE YOUR "Pacific" ELECTRIC CHAIN HOIST.



CONTENTS

Safety-Important	1
1. Foreword	3
2. Main Specification	4
2.1 Specification	4
2.2 Mechanical Classification (Grade) and Life	5
2.3 Safety Devices	6
2.4 Specifications and Dimensions	7
3. Safety Rules	9
4. Installation	11
4.1 Unpacking Information	11
4.2 Voltage	11
4.3 Installation	11
5. Operation	14
6. Maintenance and Inspection	14
6.1 Maintenance	14
6.2 Inspection	15
6.3 Overload clutch adjustment instruction.....	18
6.4 How to adjust the geared Limit Switch.....	19
6.5 Method of adjusting PEH motor brake gap.....	22
7. Troubleshooting	25
7.1 Wiring Diagrams	25
7.2 Troubleshooting and Remedial Action	28
8. Drawings and Parts Lists	29
9. CE Declaration Of Conformity	53

1. FOREWORD

This manual contains important information to help you properly install, operate and maintain the Pacific electric chain hoist and to maximize performance, economy and safety.

Please study its contents thoroughly before putting the electric chain hoist into operation. By practicing correct operating procedures and by carrying out the preventative maintenance recommendations, you will be assured of dependable service. In order to help us to supply correct spare parts quickly, please always specify -

- (1) Hoist model
- (2) Serial number
- (3) Part number, plus the description.

We trust that you will find the Pacific hoists will give you many years of satisfactory service. Should you have any queries, please contact:

Pacific Hoists Australia

24 Foundry Road

Seven Hills NSW 2147

P | +61 2 8825 6900

E | sales@pacifichoists.com.au

W | www.pacifichoists.com.au

Pacific Hoists New Zealand

11 Druces Road

Wiri Auckland NZ 2104

P | +64 9 263 5566

E | sales@pacifichoists.co.nz

W | www.pacifichoists.com.au

2.MAIN SPECIFICATIONS

2.1 Specifications

The following specifications are common to all Pacific electric chain hoists.

Table 2-1 Specifications

NB. Reverse phase relay on all models except 250kg hoist

Item		Detail	
Working temperature range (°C)		-5 to +40	
Working humidity range (%)		85 or less	
Protection	Hoist	IP 55	
	Push button	IP 65	
Electric power supply		Three Phase, 415V, 50 Hz	
Noise Level (dB)	Dual speed hoist	75	
Chain Size	Type	Nominal diameter (mm)	Pitch (mm)
	PEH050 PEH050NH	Ø6.3	19.1
	PEH100 PEH100NH	Ø7.1	20.2
	PEH200-2 PEH200-2NH	Ø7.1	20.2
	PEH200-1 PEH200-1NH	Ø10	30.2
	PEH300-2 PEH300-2NH	Ø10	30.2
	PEH500-2 PEH500-2NH	Ø11.2	34

Remarks:

- (1) Contact Pacific Hoist for information on using the hoist outside the working temperature or humidity range.
- (2) Intended use: This hoist has been designed for vertically lifting and lowering loads under normal atmospheric conditions.
- (3) Noise levels are measured at a distance of 1m horizontally from the hoists during normal operation.

2.2 Mechanical Classification (Grade) and Life

Safety and life of electric chain hoists are guaranteed only when the equipment is operated in accordance with the prescribed grade.

Pacific electric chain hoists have been designed for grade 2m in the FEM Regulations (FEM 9.5.11). Details are provided in Table 2-2. Average daily operating time and total operating time are determined by load distribution.

Table 2-2 Mechanical classification

Load Spectrum (Load distribution)	Definitions	Cubic mean value	Average daily Operation time (h)	Total operating time (h)
1 (light)	Mechanisms or parts thereof, usually subject to very small loads and in exceptional cases only to maximum loads.	$k \leq 0.50$	4 - 8	12500
2 (medium)	Mechanisms or parts thereof, usually subject to small loads but rather often to maximum loads.	$0.50 < k \leq 0.63$	2 - 4	6300
3 (heavy)	Mechanisms or parts thereof, usually subject to medium loads but frequently to maximum loads.	$0.63 < k \leq 0.80$	1 - 2	3200
4 (very heavy)	Mechanisms or parts thereof, usually subject to maximum or almost maximum loads.	$0.80 < k \leq 1.00$	0.5 - 1	1600

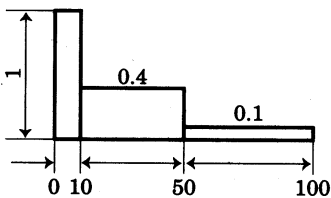

% operating time
Load spectrum 1

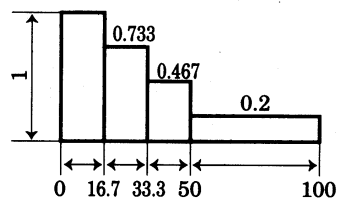

% operating time
Load spectrum 2

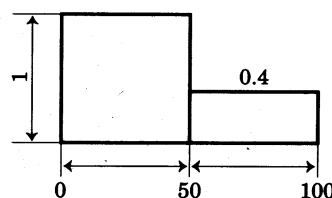

% operating time
Load spectrum 3

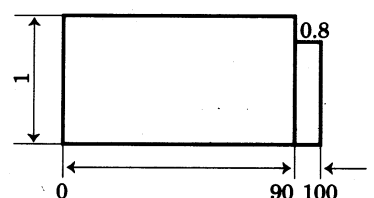

% operating time
Load spectrum 4

2.3 Safety Devices

(1) Motor brake

The "Electro-Magnetic Brake" unique design, it features simultaneous motor braking upon switching off power even under full load condition, quick action and high frequency use.

(2) Mechanical Brake w/Clutch & Overload protection device

The unique design includes mechanical brake & overload dual protection. Mechanical clutch operates with motor brake, which can offer exactly, very limited slipping & quick braking. OL device prevents over loading to damage goods, and ensure secure operation and product's life-span.

(3) Hook and hook latch

The hook is drop-forged from high tensile steel and heat treated for strength and toughness. The bottom hook is capable of 360° rotatable and fitted with a safety latch for added security.

(4) Phase Error Relay

To test 3 phases if any wrong phases connection. It can stop power once any abnormal situation to protect the hoist.

(5) Limit Switch

Upper and lower limit switches are fitted for switching off power automatically in case of over lifting or over lowering.

(6) Emergency Stop Device

This button is used to quick stop the hoist in an emergency situation. It is a red, mushroom shaped swivel button, located at the uppermost position of the pendant. When pressed, power to the equipment is switched off and the button locked automatically. Turn it clockwise can release the lock and enable re-start. (Illust.1)

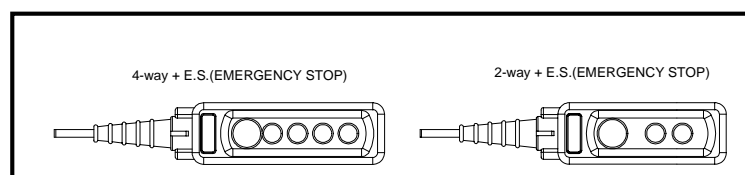

(Illust.1)

2.4 Specifications and Dimensions

a. Specifications:

Model	Capacity (kg)	Lift (m)	%E.D.	Hoisting		Traversing		Load Chain		N.W. (kg)
				Speed (m/min)	Motor kw x Pole	Speed (m/min)	Motor kw x Pole	Ø mm	Fall No.	
				50Hz		50Hz				
PEH050	500	3	40/20	10/2.5	1.1/0.28 x2/8P	20/5	0.12/0.03 x2/8P	Ø6.3 x19.1	1	47
PEH050NH			40	10	1.1x2P	20	0.12 x2P			
PEH100	1000	3	40/20	8/2	1.5/0.37 x2/8P	20/5	0.18/0.04 x2/8P	Ø7.1 x20.2	1	62
PEH100NH			40	8	1.5x2P	20	0.18x2P			
PEH200-2	2000	3	40/20	4/1	1.5/0.37 x2/8P	20/5	0.37/0.09 x2/8P		2	67
PEH200-2NH			40	4	1.5x2P	20	0.37x2P			
PEH200-1	2000	3	40/20	9.6/2.4	3.7/0.9 x2/8P	20/5	0.37/0.09 x2/8P	Ø10 x30.2	1	102
PEH200-1NH			40	9.6	3.7x2P	20	0.37x2P			
PEH300-2	3000	3	40/20	6.4/1.6	3.7/0.9 x2/8P	20/5	0.6/0.15 x2/8P		2	120
PEH300-2NH			40	6.4	3.7x2P	20	0.6x2P			
PEH500-2	5000	3	40/20	4/1	3.7/0.9 x2/8P	20/5	0.6/0.15 x2/8P	Ø11 x34	2	145
PEH500-2NH			40	4	3.7x2P	20	0.6x2P			

b. Hoisting Dimensions:

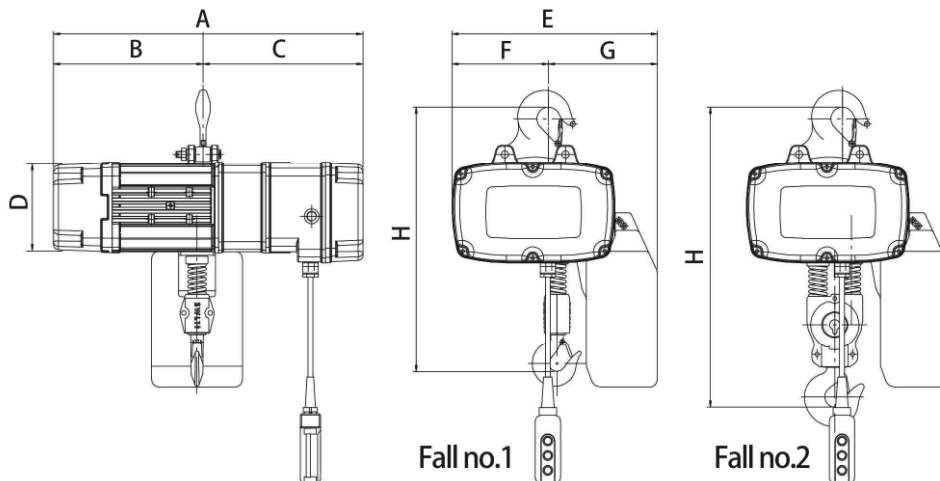

Model	Dimension(mm)							
	H	A	B	C	D	E	F	G
PEH050(NH)	500	570	270	310	165	375	190	185
PEH100(NH)	550	620	300	320	180	410	195	220
PEH200-2(NH)	620	620	300	320	180	410	195	220
PEH200-1(NH)	1020	715	340	375	220	530	270	260
PEH300-2(NH)	1050	715	340	375	220	530	270	260
PEH500-2(NH)	1100	715	340	375	220	530	270	260

c. Hoisting + Trolley Dimensions:

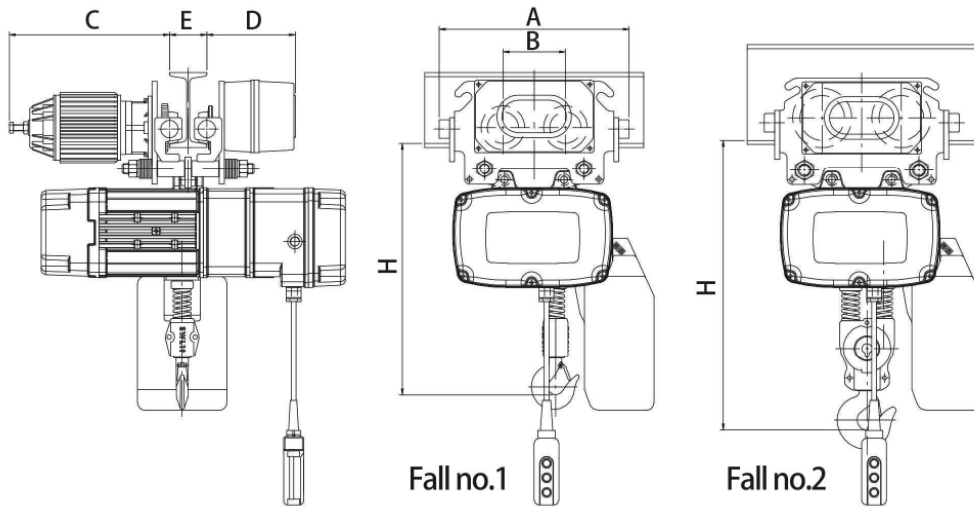

Model	Dimension(mm)					
	H	A	B	C	D	E
PEH050+PET050(055)	500	385	126	325	180	75~125
PEH100+PET100(105)	535	385	126	325	180	75~125
PEH200-2+PET200(205)	610	395	159	360	185	100~150
PEH200-1+PET210(215)	970	395	159	360	185	100~150
PEH300-2+PET310(315)	1000	445	185	400	195	125~175
PEH500-2+PET510(515)	1050	445	185	400	195	125~175

3.SAFETY RULES

DANGER

This hoist is not designed for, and should not be used for, lifting, supporting, or transporting personnel. Any modifications to upgrade, re-rate, or otherwise alter the hoist equipment must be authorized by either the original manufacturer or a qualified professional engineer.

Only trained personnel are allowed to operate the hoist.

DANGER

Do not use the hoist in explosive atmosphere.

Prior to each lifting operation, it is essential to make sure that:

- (a) the correct lifting sling is being used.
- (b) the lifting sling is located in the hook as shown below (Illust. 2) and that a safety latch has been fitted.

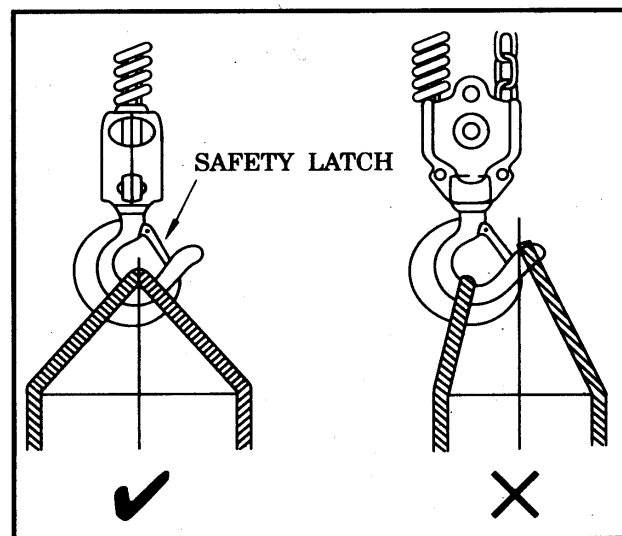

(Illust. 2)

Firm and steady button operation is required. Never push the button switch intermittently.

Always avoid excessive inching operation.

Always make sure the hoist motor completely stops before reversing.

Always leave the push button switch cable and bottom hook vertically static after completion of operation, never leave them at any position which may cause swing or slip.

Slings must be applied to load evenly and centrally to ensure correct balance. Never lift any

object which is insecure or out of balance.

Never use hoist to end or side pull a load. (Illust. 3)

Never wrap around and hook back the load chain as a sling to lift a load. (Illust. 4)

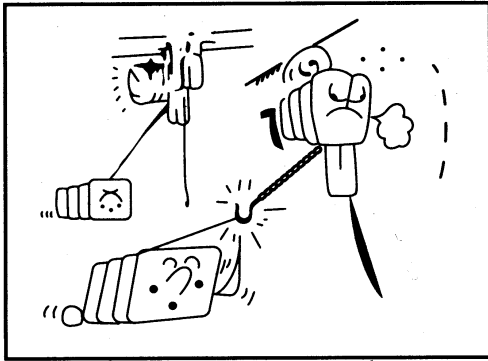

(Illust. 3)

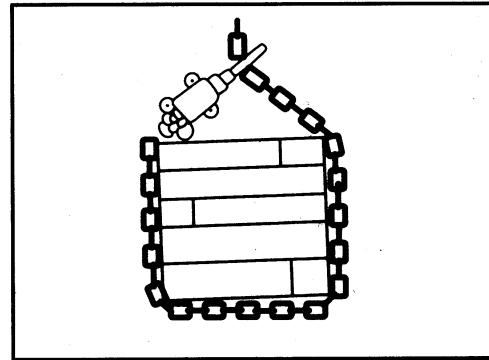

(Illust. 4)

! WARNING

Do not use the hoist chain as a welding electrode.

! DANGER

Never stand under a raised load (Illust. 5)

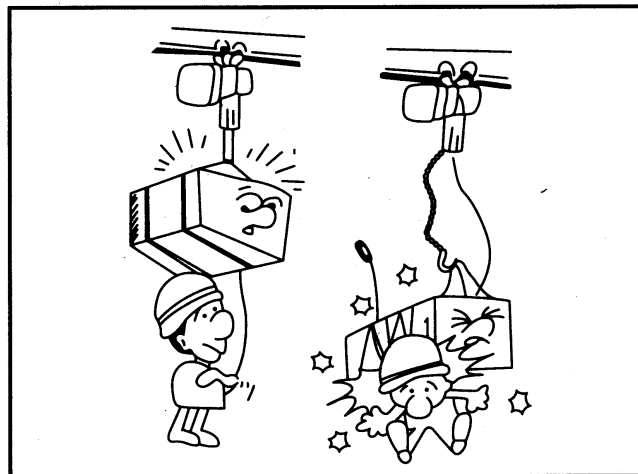

(Illust. 5)

Lifting must always be personally attended. Never leave a raised load unattended.

Over-capacity-load lifting is hazardous and should not be undertaken.

Never lift a load when the load chain is twisted.

Regularly inspect and check the condition of load chain. Do not operate with damaged chain.

4. INSTALLATION

4.1 Unpacking Information

After removing the hoist from its packing box, carefully inspect the external condition of the electrical cables, contactor, gearbox and motor casing for damage.

Check and ensure that these items are present.

Each hoist is supplied as standard with the following accessories.

1. Chain bucket	1 set
2. Power cable	0.5 meter
3. Push button control switch	1 piece

Table. 4-1

4.2 Voltage

CAUTION

If power supply deviates from standard by more than $\pm 10\%$ abnormal operation or damage to the motor may result. It is imperative to ensure correct voltage supply before commencing operation.

4.3 Installation

WARNING

Connection to power supply before installation procedures having been completed is strictly prohibited.

Prior to installation check and ensure that the top hook assembly is securely attached to the hoist by means of the lock bolt.

When fitting the top hook ensure the direction of the hook is correct for the model of the hoists, as indicated by the sticker adjacent to the hook attachment.

NOTE: If the hoist is to be suspended from an electric trolley, assembly may be eased by firstly removing the top hook, attaching it to the trolley load plate, then refitting the top hook to the hoist.

Assemble chain bucket —

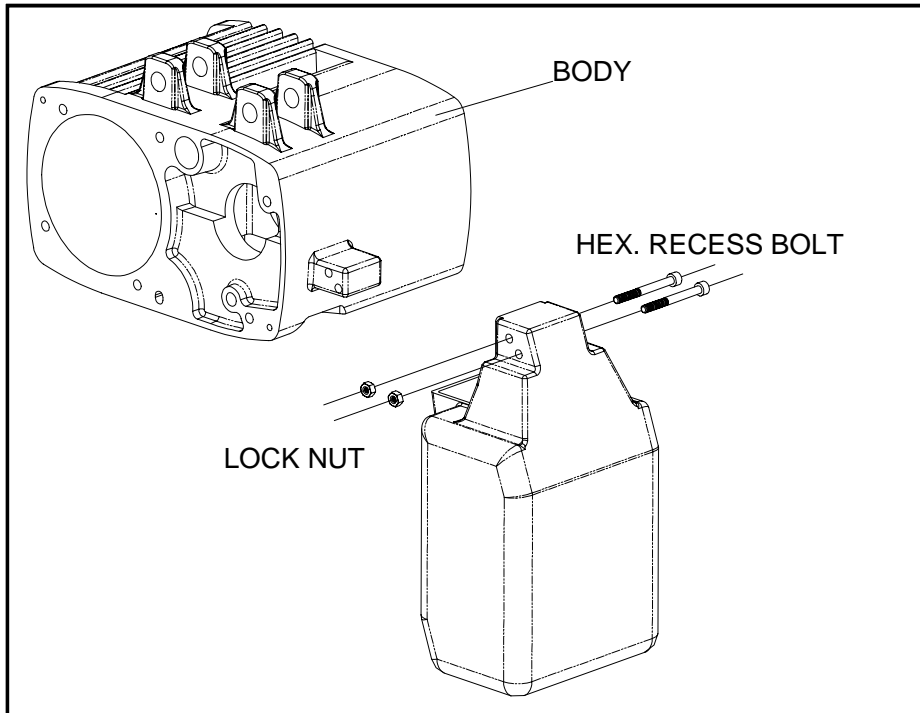



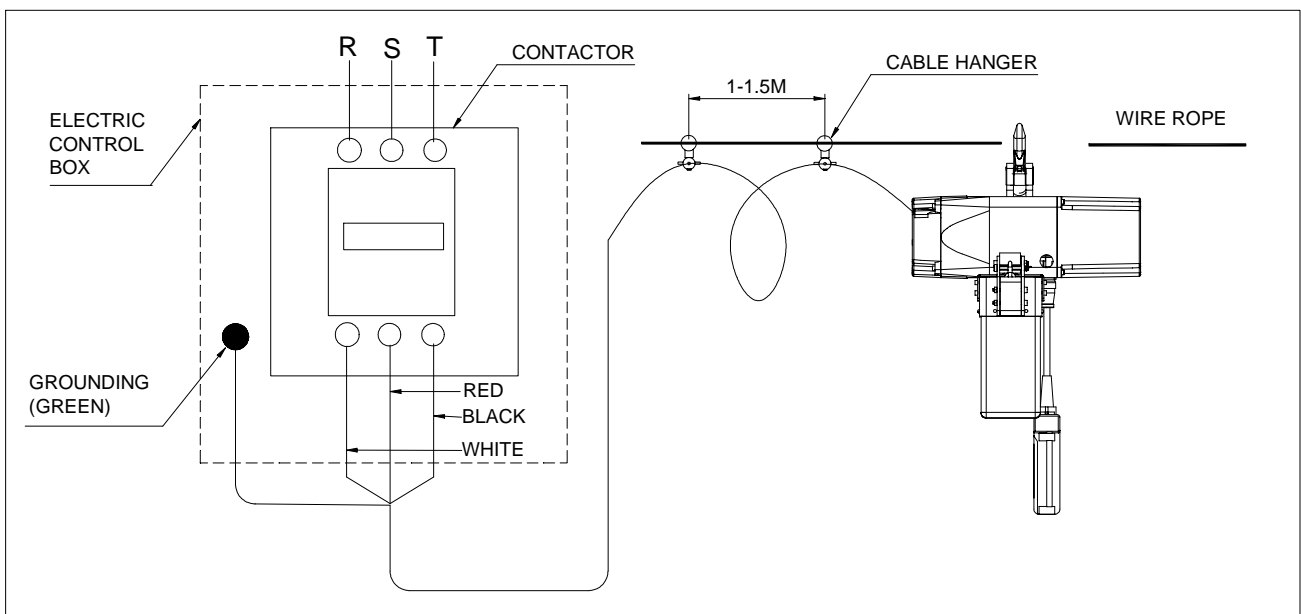

(Illust. 6)

Connect power supply to hoist and operate the push button switch. This operation must be carried out by a trained person.



(Illust. 7)

Operation Test

- (a) Please reverse any two connections while the direction is incorrect.
- (b) Firmly push  switch button to lower load chain until the limit spring touches the limit switch. Power should be cut off automatically.
- (c) Firmly push  switch button to check the collection of load chain into chain bucket.
- (d) Check the emergency stop device function :
While holding down either  or  button on the push button switch, push the emergency stop button. Check that the hook stops when the emergency stop button is pushed. Also, check the hoist does not move in response to the push button switch.
Finally, check that the emergency stop device pops out when turned to the right and that operation can be resumed thereafter. If the equipment fails to pass any of the above checks, check the wiring and automatic locking function of the emergency stop device.
- (e) Check load chain lubrication (It has been lubricated at our works, but the lubricant may dry out during transportation). It is also advisable to keep a small amount of lubricant in the chain bucket to keep the chain in an oil bath.
- (f) Check chain position. Weld joints on links must face the same direction (Illust. 8). Correct chain operation can only be achieved when all joints are vertically in line.

CAUTION

The bottom hook on multi-fall hoist must never be rotated as shown below.
(Illust. 9)

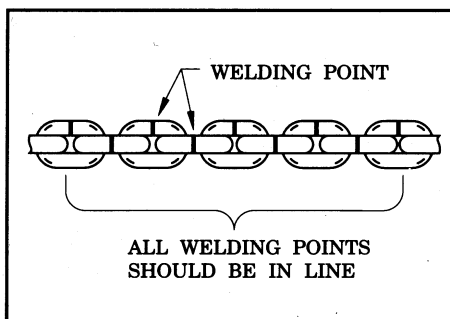

Illust. 8

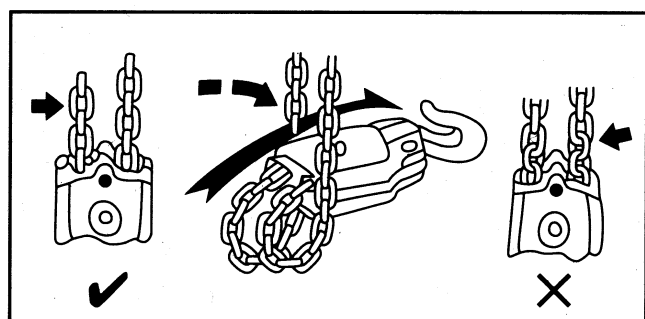

Illust. 9

5. OPERATION

After running test and checks have been completed, the hoist will be ready for normal operation.

WARNING

Since dealing with heavy loads may involve unexpected danger all of the "SAFETY RULES" (Ref 3.) must be followed and the operator must be aware of the following points while using the hoist.

- (1) The operator must have a clear and unobstructed view of the entire working area before operating the hoist.
- (2) The operator must check that the entire working area is safe and secure before operating the hoist.
- (3) When using the hoist with a motorized trolley, the operator must take care to prevent excessive load swinging by sympathetic use of the trolley controls

6. MAINTENANCE AND INSPECTION

DANGER

Do not perform maintenance on the hoist while it is carrying a load except monthly checking for the brake or limit switch.

DANGER

Before performing maintenance do not forget to affix tags to the power source and the push button switch reading : "DANGER", "EQUIPMENT BEING REPAIRED".

6.1 Maintenance

- (1) Check the level of gearbox lubricant after the first 500 hours operation, thereafter check every 3 months and lubricate accordingly.

NOTE: We recommend using lubricant oil equivalent to SHELL S4 WE460.

- (2) Always keep the hoist unit dry and never misuse it in a manner likely to reduce its durability.
- (3) When it is necessary to keep the unit outdoors, a protective covering should be fitted.

6.2 Inspection

1. Daily inspection: Before starting daily operation, check the followings:

- (a) Correct power supply.
- (b) "Up", "Down" and "Emergency Stop" test runs under no load.
- (c) Correct motor performance.
- (d) No abnormal or excessive noise.
- (e) No malfunction of the bottom hook safety latch.
- (f) Proper function of moving/turning parts and brake.
- (g) Well-lubricated load chain.

2. Monthly inspection

(a) Load chain.

Distorted, elongated or worn chain link will not sit properly on the load sprocket wheel and may cause chain breakage and/or damage to hoist unit. To ensure safe and efficient operation, the chain links must be checked for their pitch (inside length), inside width and outside width monthly according to following table.

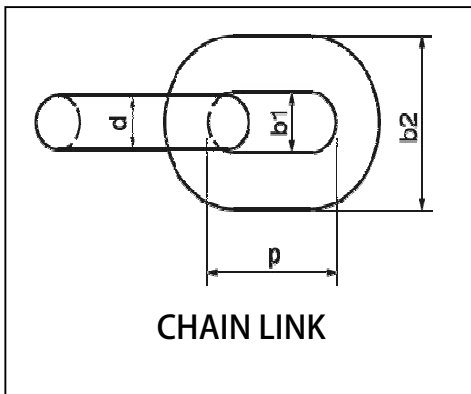

Dia-Meter (m/m) (d)	Model	Inside Length (m/m) (p)	Inside Width (m/m) (b1)	Outside Width (m/m) (b2)	Breaking Load (kn)
Ø6.3	PEH050(NH)	19.1	7.9	21.4	50
Ø7.1	PEH100(NH) PEH200-2(NH)	20.2	8.1	23.2	63.3
Ø10.0	PEH200-1(NH) PEH300-2(NH)	30.2	12.5	33.2	128
Ø11.2	PEH500-2(NH)	34	14	37.5	160

Table 6-2-a

Measuring

! WARNING

Always use the hoist manufacturer's recommended parts when repairing a hoist.

- (1) The chain gauge is useful and convenience for measuring.
- (2) Please use a chain gauge to measure the chain pitch and diameter, per illustrations (1) and (2).
- (3) Every chain ring must be measured, and the chain must be replaced when one of chain ring is wear or stretch.
- (4) It will be a cutting-out possibility if you use a chain fall either wear or stretch during operation.
- (5) Do not replace a chain fall by yourself and do please contact specific either service centers or contractors to help you out.
- (6) The chain fall must be replaced whole instead of in part.

(7) The load sheave, regulator, and regulator plate wheel must be replaced the same time as you do a chain replacement.

Note : Chain must be in perfect condition without any defects.

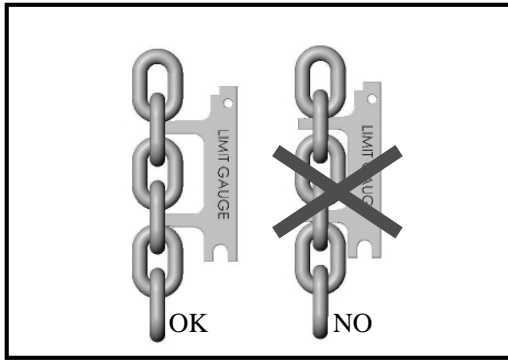

Illustration (1) Chain pitch measure

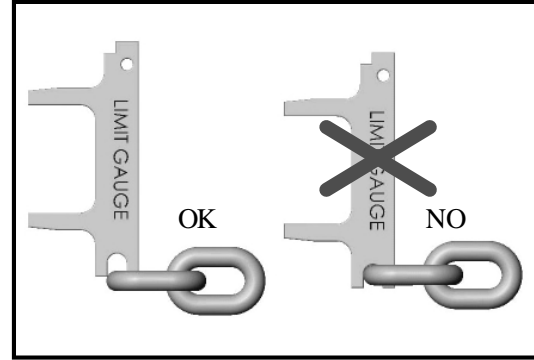
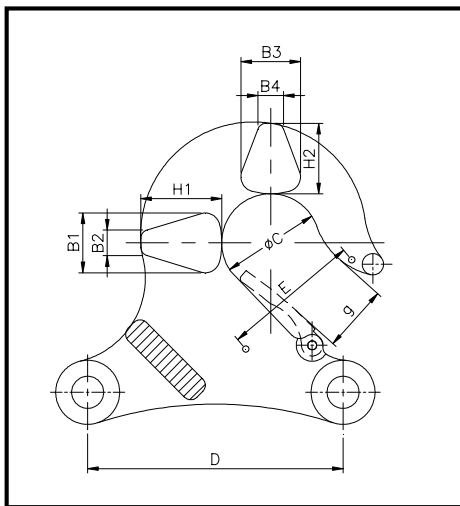
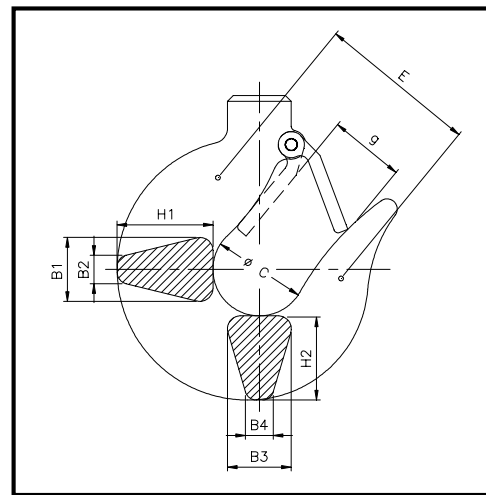

Illustration (2) Diameter measure

(b) Check hook with care. If hook shows cracks, deformation or excessive wear, it should be replaced.



Top Hook



Bottom Hook

Model	Capacity (kg)	Hook	Dimensions (mm)										Allow Stress (kg/mm ²)
			H1	B1	B2	H2	B3	B4	C	D	g	E	
PEH050	500	T	33	22	10	29	22	10	40	95.5	25.5	55	70
PEH050NH		B	28	18	8	23	18	8	35	-	26	50	70
PEH100	1000	T	38	28	12	33	28	12	46	120	31	65	100
PEH100NH		B	33	23	9	29	23	9	40	-	28	61	70
PEH200-2	2000	T	38	28	12	33	28	12	46	120	31	65	100
PEH200-2NH		B	45	31	10	41	31	10	46	-	36	75	70
PEH200-1	2000	T	55	34	19	48	34	19	52	-	40	90	70
PEH200-1NH		B	55	34	19	48	34	19	52	-	40	90	70
PEH300-2	3000	T	55	34	19	48	34	19	52	-	40	90	70
PEH300-2NH		B	55	34	19	48	34	19	52	-	40	90	70
PEH500-2	5000	T	66	44	23	60	44	23	62	-	45	100	70
PEH500-2NH		B	66	44	23	60	44	23	62	-	45	100	70

Top Hook=T Bottom Hook=B

3. Annual inspection



Your dealer should be asked to perform this inspection.

- (a) Check gearing for any excessive wears or damage.
- (b) Replace gearbox lubricant completely (PEH050(NH) / 800C.C., PEH100(NH) & PEH200-2(NH) / 1400C., PEH200-1(NH) & PEH300-2(NH) & PEH500-2(NH) /4000C.C.) as following table for your reference. NOTE: We recommend using lubricant oil equivalent to SHELL S4 WE460.

※ Table of recommended oils according to DIN 51354

ISO-VGDIN 51519 viscosity At 40°C mm ² /s (cST)	Approximate viscosity of the VG Categories 50°C mm ² /s (cST)	ARAL	BP	ESSO	MOBIL OIL
VG460	251	Aral Degol BG 460-BMB 460	BP Energol GR-XP 460	Spartan EP-460	Mobilgear 634

ISO-VGDIN 51519 Viscosity at 40°C mm ² /s (cST)	Approximate viscosity of the VG Categories 50°C mm ² /s (cST)	SHELL	TEXACO	I.P.	AGIP	TOTAL
VG460	251	Omala oil S4 WE460	Meropa 460	Mellana 460	Blasia 460	Carter EP 460

Table 6-2-b



The permissible tolerance for each VG category is $\pm 10\%$ of the tabulated values.

- (a) Check brake lining for any wear or damage.
- (b) On completion of above checks, lift a load several times to ensure good performance of the hoist before starting duty operation.

Warranty Details

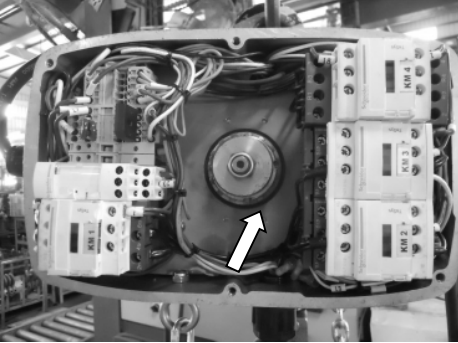
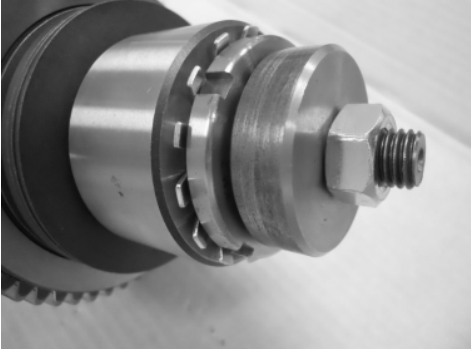
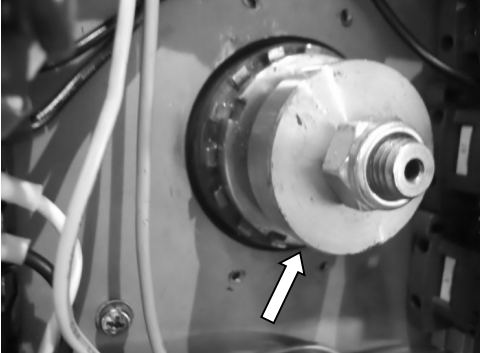

1. Warranty Period : One year for Mechanical Spare Parts after purchase the product.
2. Non-Warranty Scope:
 - (a) Electrical Spare Parts (ex. Contactor, Pendant, Phase Error Relay, etc.)
 - (b) Expense Spare Parts (ex. Chain Bucket, Brake Lining, etc.)
 - (c) Damage caused by unsuitable operation.
(ex. Galvanize plant, Chemical Plant, Dye-work, etc.)
 - (d) Damage caused by operating on the wrong electric voltage.
 - (e) Damage caused by user amend the product.
 - (f) Damage caused by natural disaster.
3. Warranty Scope shall be permitted by Cheng Day Machinery and Within One Year of damaged Mechanical Spare Parts Repair and Replacement.
(circumstance stated in detail No. 2 are not included.)

6.3 Overload clutch adjustment instructions

Description	Picture
<p>Mechanical Brake and Overload Protection</p>	
<p>Setting is 125% rated load</p> <ol style="list-style-type: none"> 1. Use rolling bearing nut fixture to tighten the clutch nut fixture. 2. It can be able to lift in 100% rated load. 3. Adjust the load to 125% rated load 4. Clutch is slipping, cannot lift, setting complete. 5. Setting the clutch does not slip when lifting a load 6. Loosen the adjusting nut, and set the clutch slip, be unable to lift the load. 7. Adjust load to 100% rated load, clutch does not slip and can be able to lift the load. 8. Adjust the load to 125% rated load, clutch slip the loading material. Setting complete. 9. Setting of overload is 100% rated load can be able to lift and 125% rated load have to slip. 	 
<p>After setting complete, level rolling bearing nut washer at nut groove, tap washer to secure it, to prevent loosening.</p> <p>Adjust load to 100% rated load, It is able to lift in 100% rated load, Setting complete.</p>	 

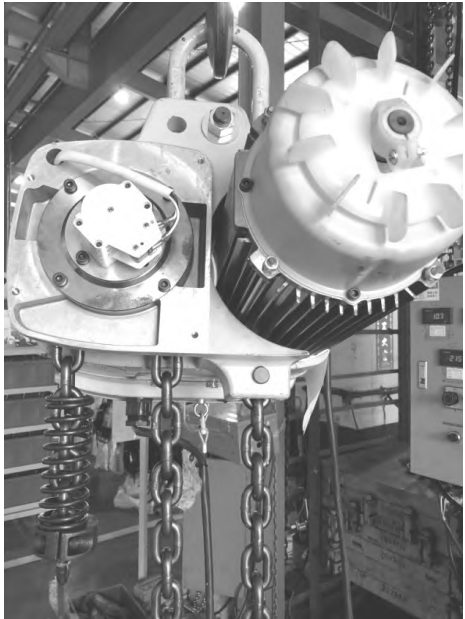
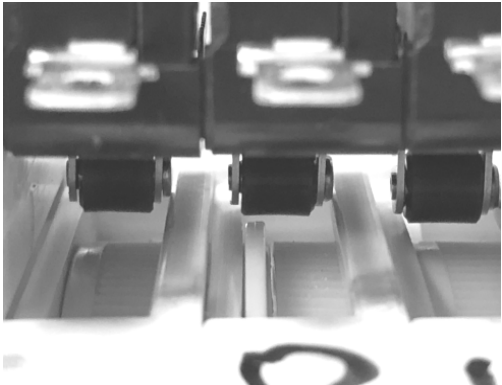
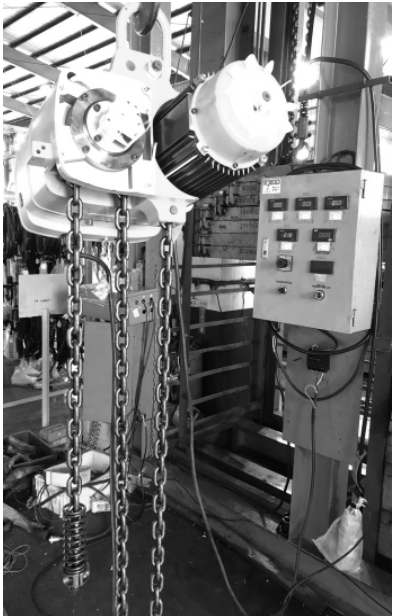
6.4 How to adjust the geared Limit Switch for PEH200-1(NH)/ PEH 300-2(NH)/ PEH500-2(NH)

Description	Picture
<p>1. Put in load chain from the side of chain bag and goes through chain sprocket, press the pendant (down) button, let the chain be at Lower Limit Switch position.</p>	
<p>2. Lower L/S flange set up to be close to the middle (you can see there are 3 switch, the middle one). Adjust Plastic screw by using #4 Hex wrench.</p>	
<p>3. When the chain tail at lower LS is too longer.</p>	

Description	Picture
<p>4. Adjust lower L/S plastic screw (the middle one) by clockwise direction, the chain shortens. While adjust it by counterclockwise direction, the chain tail becomes longer. Once touch the LS, it needs to back off the distance about 1 meter. After L/S trips off, it can be re-adjust again.</p>	
<p>5. The suitable chain tail location is 300-400mm. Need to double check if it stops at correct location after completing the adjustment.</p>	
<p>6. Press push button UP, let the bottom hook be at right location for Upper Limit Switch if the hook position is too longer.</p>	

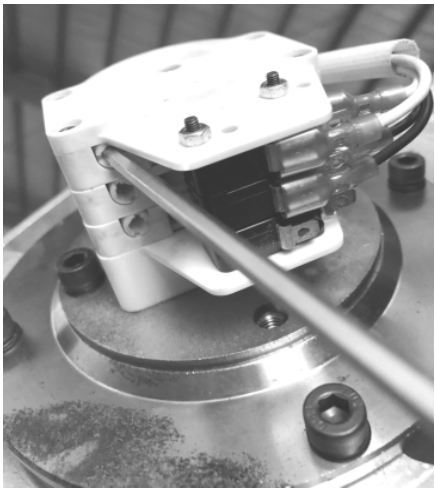
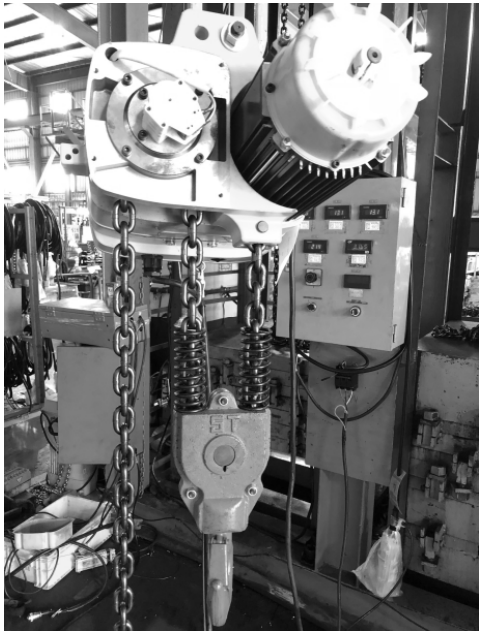
Description	Picture
<p>7. Counterclockwise direction to set up upper LS plastic screw, see the photo. Adjust counterclockwise direction if bottom hook at too longer position. If it' s too short, clockwise to adjust it. Once touch the LS, it needs to back off the distance about 1 meter. After L/S trips off, it can be re-adjust again</p>	
<p>8. Adjust it till the bottom hook is at right position (about 300-400mm), double check and test to make sure it' s completed.</p>	

Please note

1. When adjust the plastic screw, face to L/S like below photo direction.
2. Check the plastic screw, if turning wrong direction, adjust it by opposite direction. Need to re-test and check if position is correct.
3. Once touch the LS, it needs to back off the distance about 1 meter. After L/S trips off, it can be re-adjust again

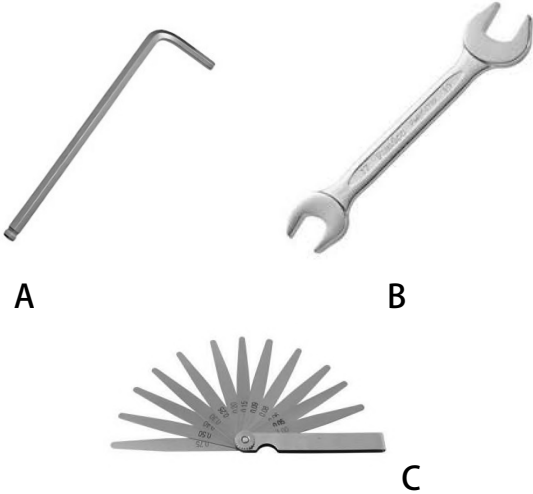
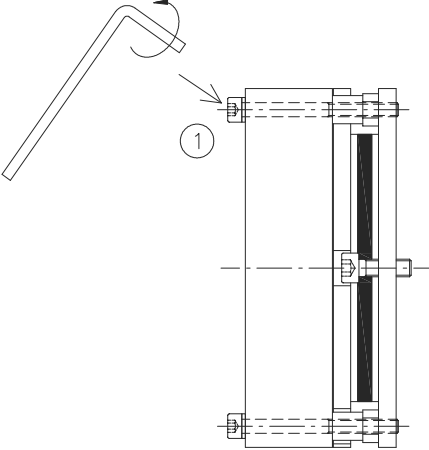
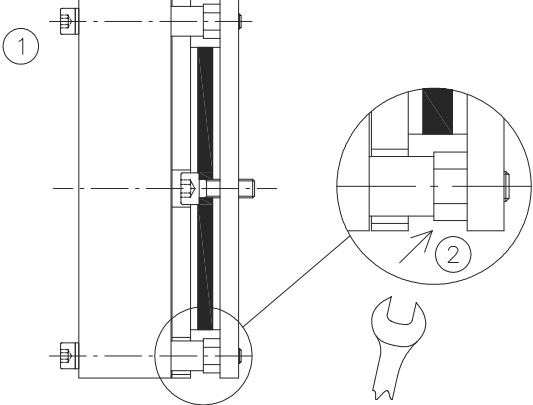

6.5 Method of adjusting PEH motor brake gap <PEH050-1/PEH100-2>

Time to adjust	
<ol style="list-style-type: none"> 1 When the brake function affects the operation of hoist 2 Brake lining motion causes abnormal noise 3 Brake gap is over 0.7mm. <p>※Note : To prevent risks , the hoist must be in unload and power-off during the adjustment</p>	
Tools needed	Figure
<ol style="list-style-type: none"> A. Hex Wrench B. Open-end wrench C. Thickness gauge 	 <p>The figure displays three tools: a hex wrench labeled 'A', an open-end wrench labeled 'B', and a thickness gauge labeled 'C'.</p>
Method of adjusting	Figure
<ol style="list-style-type: none"> 1. Use hex wrench to loosen ①set screw 	 <p>The diagram shows a cross-section of the brake assembly. A hex wrench is shown with an arrow indicating it is being used to turn a set screw, labeled with a circled '1', to loosen it.</p>
<ol style="list-style-type: none"> 2. Use Open-end wrench to turn the Hex Head of ②distance ring and adjust the height of ②distance ring. 3. Once adjusted ②distance ring, need to tighten the set screw before measuring the gap. 	 <p>The diagram shows the same cross-section. A circled '1' points to the set screw. A circled '2' points to the hex head of the distance ring. An inset shows a close-up of the distance ring being turned. An open-end wrench is shown below the inset, indicating it is used to turn the hex head.</p>

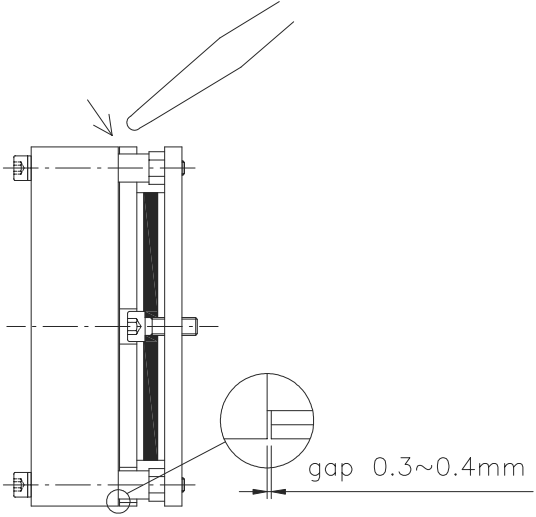
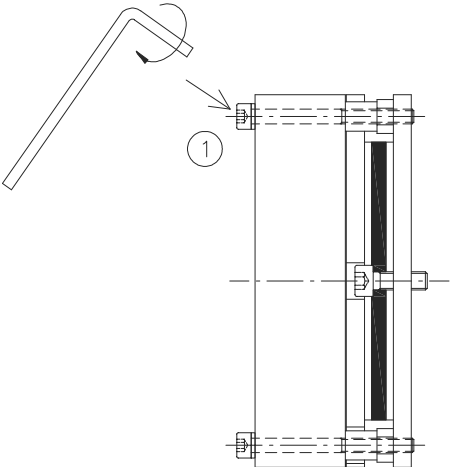
Method of adjusting	Figure
<p>4. Apply with thickness gauge when adjusting the gap.</p> <p>At least 3- 4 measuring points.</p> <p>5. Gap value : about 0.3~0.4mm.</p>	 <p>The diagram shows a vertical assembly with a central shaft and a surrounding housing. A thickness gauge is positioned at the top, with an arrow pointing to the gap between the gauge and the housing. A circular inset provides a magnified view of the gap, with a dimension line indicating a gap of 0.3~0.4mm.</p>
<p>5. Make sure all measuring points reach gap value. Then tighten the ①set screw.</p> <p>6. Check the gap again. If there is an error, re-adjust again.</p>	 <p>The diagram shows the same vertical assembly. A set screw, labeled with a circled '1', is being tightened against the top of the housing. An arrow indicates the direction of rotation for the set screw. The thickness gauge is no longer present.</p>

7.TROUBLESHOOTING

7.1 Wiring Diagrams

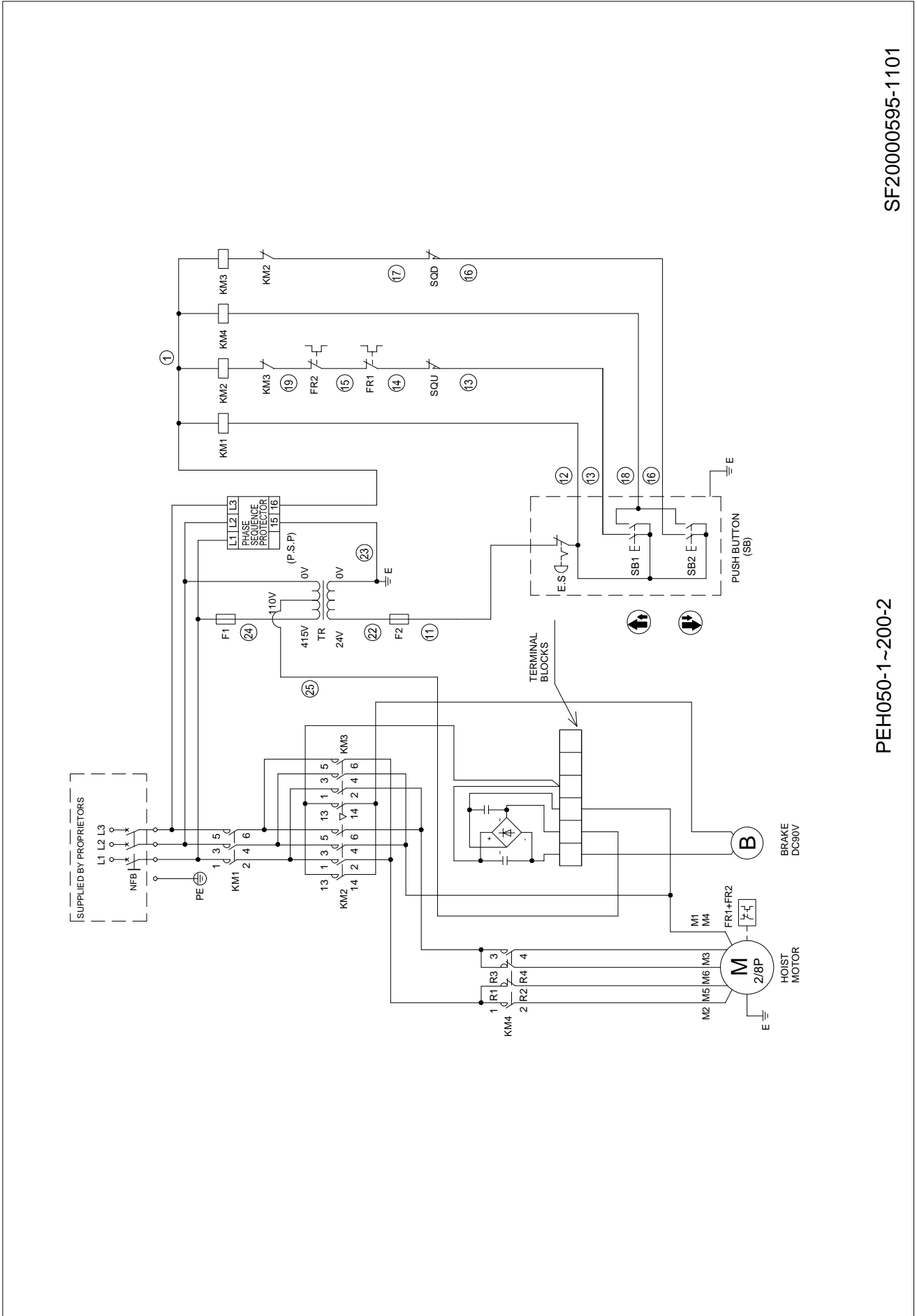

SF20000595-1101

PEH050-1~200-2

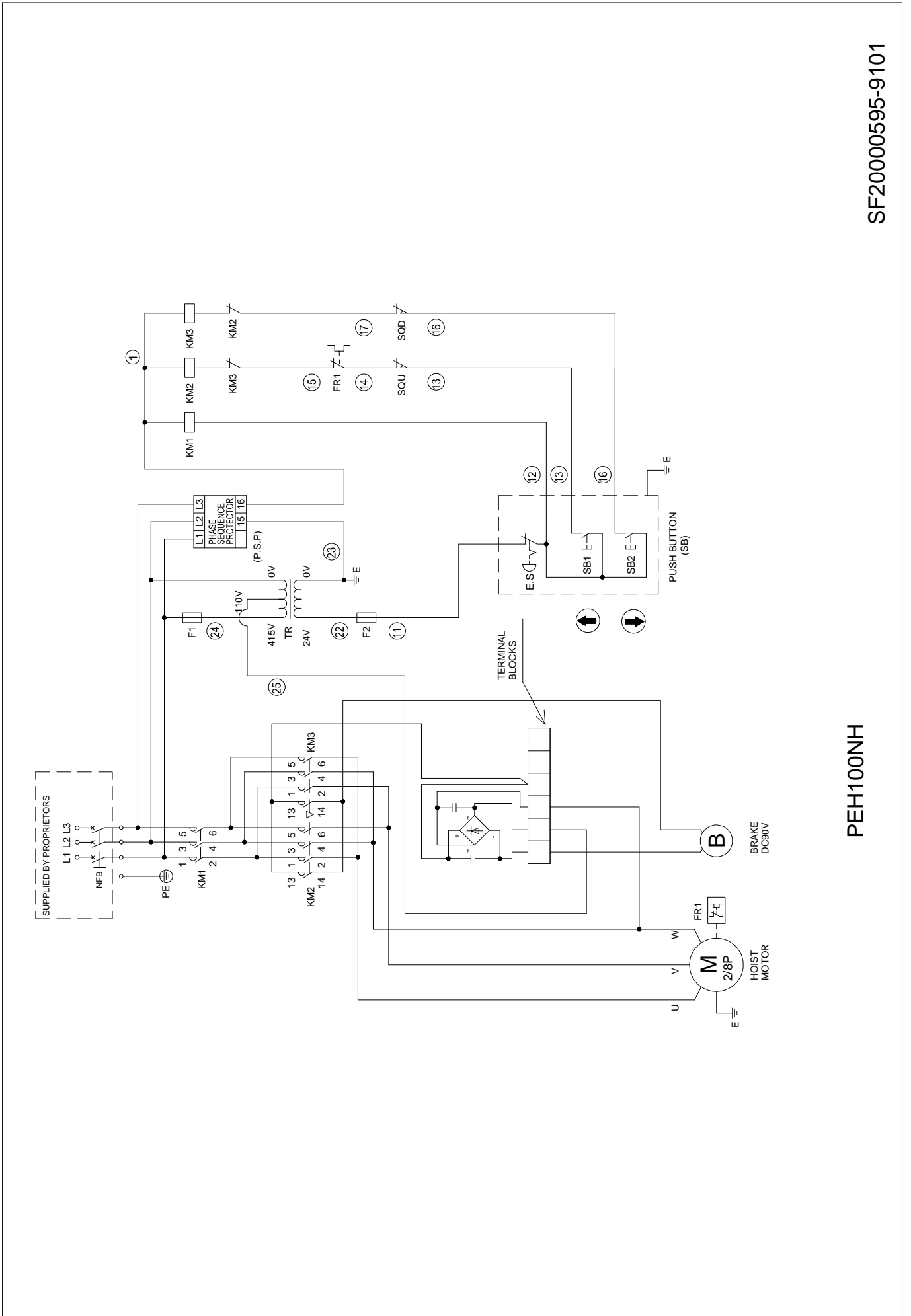

PEH100NH

SF20000595-9101

7.2 Troubleshooting and Remedial Action

SITUATION	CAUSE	REMEDY
Hoist will not operate	<p>(1) Broken/disconnected power or control circuit wire.</p> <p>(2) Low supply voltage</p> <p>(3) Motor hums but does not rotate</p> <p>(4) Emergency stop button release pushed</p> <p>(5) Faulty contactor</p>	<p>Locate and repair/reconnect</p> <p>Check if 10% reduction in voltage, have main supply checked</p> <p>Check phases to motor-insulate and repair</p> <p>Check the cause as necessary</p> <p>Operate manually if hoist runs then control circuit/coil is faulty-locate fault and repair. If hoist does not run then check main supply. If input supply is correct but there is a faulty output supply then replace the contactor</p>
Hoist will not stop	Welded contacts in contactor	Replace contactor
Brake slips	Abrasion of motor brake	Replace
Hoist runs but does not lift	(1) Clutch slipping	Contact your authorized Pacific dealer — this adjustment needs to be carried out on a test rig
Abnormal sound on load chain/chain sprocket (2 falls)	<p>(1) Chain dry</p> <p>(2) Worn chain sprocket (2 falls)</p>	<p>Lubricate</p> <p>Replace load chain and chain sprocket (2 falls)</p>
Electric shock	<p>(1) Poor earth connection</p> <p>(2) Accumulated foreign matter/ moisture on electrical parts</p>	<p>Provide correct earth connection</p> <p>Remove foreign matter/dry electrical parts</p>
Oil leak	<p>(1) No oil plug</p> <p>(2) Loose fitting of oil plug</p> <p>(3) No plug packing</p> <p>(4) Worn or deteriorated oil packing</p>	<p>Attach the normal oil plug</p> <p>Fasten the plug tightly</p> <p>Attach normal packing</p> <p>Attach the new packing</p>

8. DRAWINGS AND PARTS LISTS

(1) MOTOR ASSEMBLY & HOUSING B.O.M	30~35
(2) HOOK ASSEMBLY B.O.M	36~41
(3) GEARBOX ASSEMBLY B.O.M	42~47
(4) ELECTRIC ASSEMBLY B.O.M	48~52

MOTOR EXPLOSION & HOUSING

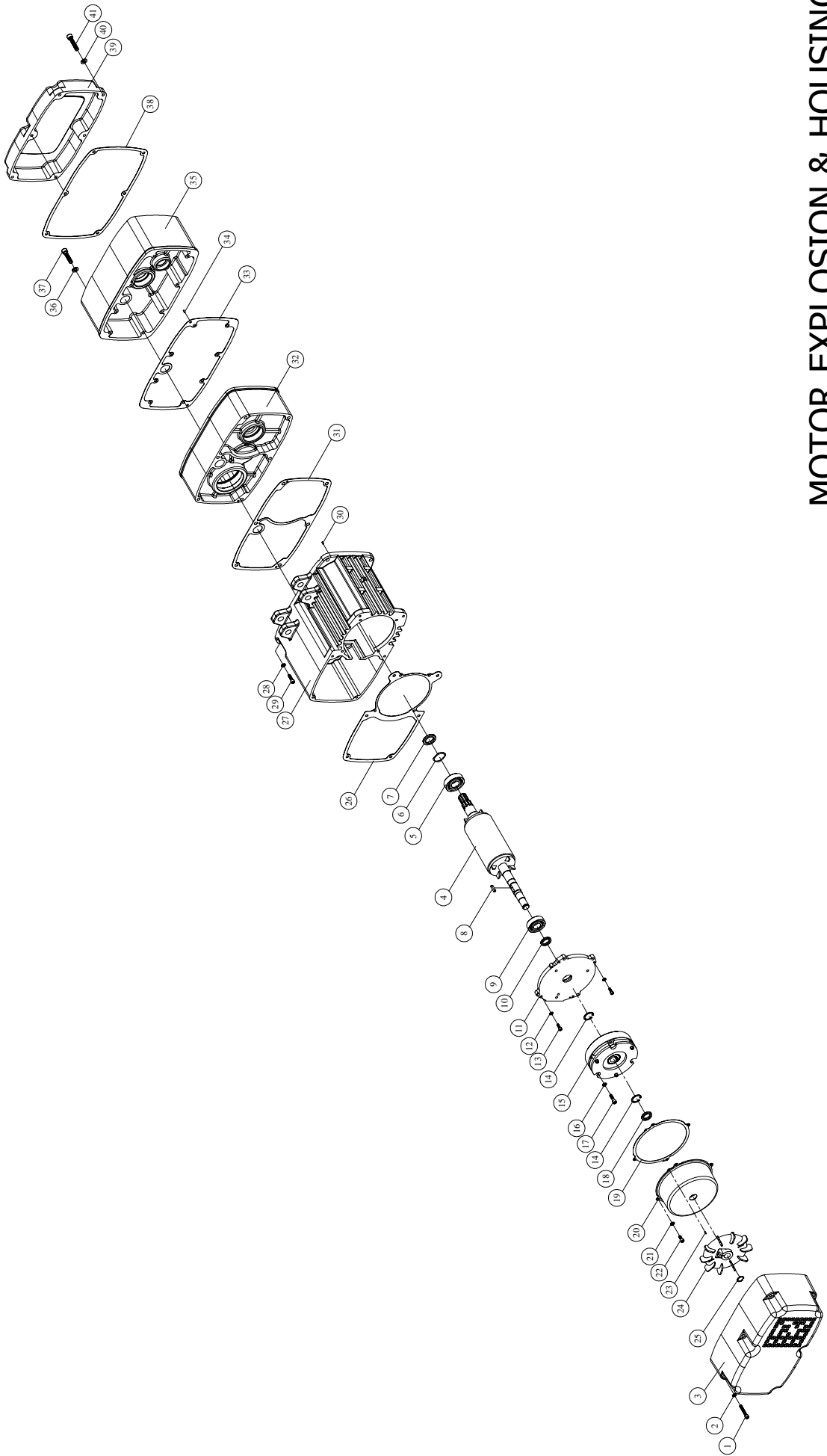

MOTOR ASSEMBLY & HOUSING

NO.	PARTS CODE	DESCRIPTION	Q'TY REQ'D EACH UNIT	
			PEH050(NH)	PEH100(NH) PEH200-2(NH)
1	408330	Hex. Recess Bolt <M5 × 0.8 × 45>	6	
	408661	Hex. Recess Bolt <M6 × 1.0 × 75>		6
2	400854	Spring Washer <M5>	6	
	400855	Spring Washer <M6>		6
3	115425L	End Cover	1	
	301458L			1
4	108279	Motor Rotor	1	
	108280			1
5	405577	Bearing <6204 2RS>	1	
	400143	Bearing <6205 ZZ>		1
6	407553	Wave Washer <6205>		1
7	400186	Oil Seal < Ø20 × Ø35 × 8t>	1	
	400891	Oil Seal <Ø25 × Ø 45 × 8t>		1
8	405925	Key <t6 × 6 × 20L>	1	1
9	405577	Bearing <6204 2RS>	1	
	400808	Bearing <6304 ZZ>		1
10	400186	Oil Seal < Ø20 × Ø35 × 8t>	1	1
11	105920	Motor End Cover	1	
	105918			1
12	400854	Spring Washer <M5>	4	
	400855	Spring Washer <M6>		4
13	408329	Hex. Recess Bolt <M5 × 0.8 × 20>	4	
	408333	Hex. Recess Bolt <M6 × 1.0 × 25>		4
14	404182	Retaining Ring <S-19>	2	2
15	100516	Brake Ass'y <SNT-102-075>	1	
	106949	Brake Ass'y <TSB-124-150>		1
16	400855	Spring Washer <M6>		3
17	408660	Hex. Recess Bolt <M6 × 1.0 × 35>		3
18	404533	Oil Seal <VA18>	1	1
19	402446	Brake End Cover Gasket	1	
	402696			1
20	108195	Brake End Cover	1	
	108742			1
21	400854	Spring Washer <M5>	4	4
22	408662	Hex. Recess Bolt <M5 × 0.8 × 10>	4	4

MOTOR ASSEMBLY & HOUSING

NO.	PARTS CODE	DESCRIPTION	Q'TY REQ'D EACH UNIT	
			PEH050(NH)	PEH100(NH) PEH200-2(NH)
23	400295	Pin < Ø3 × 10 >		2
24	100563	Fan < Ø124 × Ø14 >	1	
	107909	Fan < Ø138 × Ø16 >		1
25	404001	Retaining Ring <S-14>	1	
	400190	Retaining Ring <S-16>		1
26	402660	End Cover Gasket	1	
	402508			1
27	106038N	Motor Stator Ass'y <1.1/0.28KW 2/8P>	1	
	106659N	Motor Stator Ass'y <1.5/0.37KW 2/8P>		1
	102672N	Motor Stator Ass'y <1.1KW 2P>	1(NH)	
	102676N	Motor Stator Ass'y <1.5KW 2P>		1(NH)
28	400856	Spring Washer <M8>	6	6
29	408346	Hex. Bolt <M8 × 1.25 × 35>	6	
	408340	Hex. Bolt <M8 × 1.25 × 30>		6
30	400615	Pin < Ø5 × 12>	2	2
31	402664	Motor Gasket	1	
	402559			1
32	200830N	Gearbox	1	
	208858N			1
33	402445	Gearbox Gasket	1	
	402560			1
34	400615	Pin < Ø5 × 12>	2	2
35	205610L	Gearbox Cover	1	
	205515L			1
36	400094	Spring Washer <M6>	6	8
37	400010	Hex. Recess Bolt <M6 × 1.0 × 55>	6	
	408413	Hex. Recess Bolt <M6 × 1.0 × 85>		8
38	402590	Electric Cover Gasket	1	
	402697			1
39	300716L	Electric Cover	1	
	300306L			1
40	400855	Spring Washer <M6>	8	6
41	408335	Hex. Recess Bolt <M6 × 1.0 × 40>	8	
	408660	Hex. Recess Bolt <M6 × 1.0 × 35>		6

MOTOR EXPLOSION & HOUSING

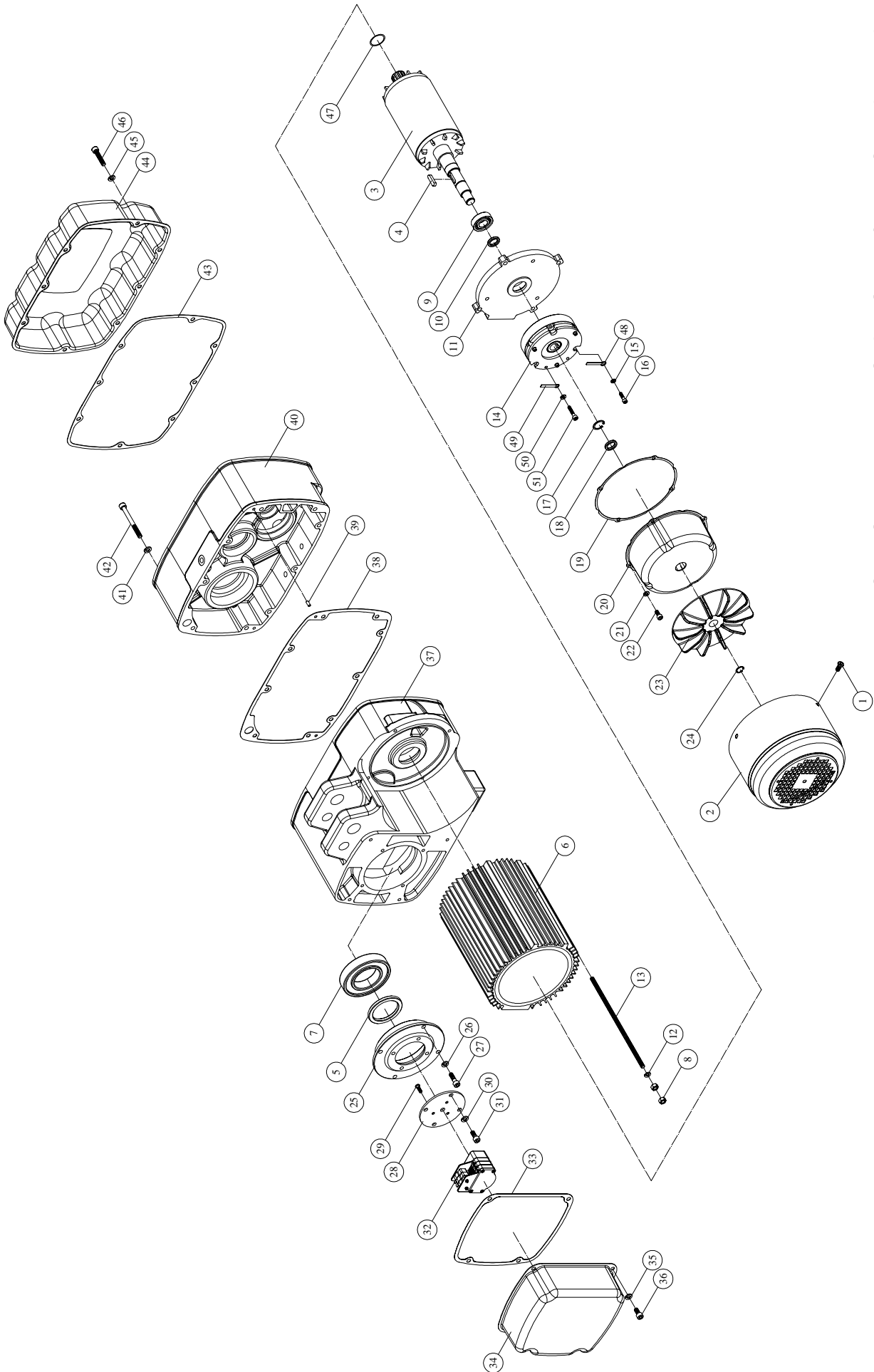

MOTOR ASSEMBLY & HOUSING

NO.	PARTS CODE	DESCRIPTION	QTY REQ'D EACH UNIT		
			PEH200-1(NH)	PEH300-2(NH)	PEH500-2(NH)
1	400620	Cross Headed Screw <M5 × 0.8 × 8>	4	4	4
2	105444L	End Cover	1	1	1
3	100306	Motor Rotor	1	1	1
4	405926	Key <t7 × 7 × 25L>	1	1	1
5	400944	Oil Seal <Ø45 × Ø60 × 8t>	1	1	1
6	106100N	Motor Stator Ass'y <3.7/0.9kw 2/8P>	1	1	1
	102569N	Motor Stator Ass'y <3.7kw 2P>	1(NH)	1(NH)	1(NH)
7	407821	Bearing <6310 ZZ>	1	1	1
8	400081	Nut. < M8 × 1.25>	8	8	8
9	400113	Bearing <6206 2RU>	1	1	1
10	400934	Oil Seal < Ø30 × Ø50 × 8t>	1	1	1
11	105919	Motor End Cover	1	1	1
12	400095	Spring Washer <M8>	4	4	4
13	408209	Threaded bar <M8 × 1.25 × 290L>	4	4	4
14	105538	Brake Ass'y TSB-165-370	1	1	1
15	400095	Spring Washer <M8>	3	3	3
16	400016	Hex. Recess Bolt <M8 × 1.25 × 60L>	3	3	3
17	404183	Retaining Ring <S-24>	1	1	1
18	404556	Oil Seal <VA22>	1	1	1
19	402449	Brake End Cover Gasket	1	1	1
20	108755	Brake End Cover	1	1	1
21	400094	Spring Washer <M6>	4	4	4
22	400421	Hex. Recess Bolt <M6 × 0.8 × 10L>	4	4	4
23	105490	Fan < Ø165 × Ø19 odd>	1	1	1
24	404182	Retaining Ring <S-19>	1	1	1
25	268550	Bearing Housing	1	1	1
26	400095	Spring Washer <M8>	4	4	4
27	400012	Hex. Recess Bolt <M8 × 1.25 × 20L>	4	4	4
28	217220	Limit Plate	1	1	1
29	406848	Socket Head Cap Screws <M5 × 0.8 × 10>	3	3	3
30	400095	Spring Washer <M8>	4	4	4
31	400011	Hex. Recess Bolt <M8 × 1.25 × 12L>	4	4	4

MOTOR ASSEMBLY & HOUSING

NO.	PARTS CODE	DESCRIPTION	QTY REQ'D EACH UNIT		
			PEH200-1(NH)	PEH300-2(NH)	PEH500-2(NH)
32	268511	Limit Switch	1	1	1
33	402448	Limit Cover Gasket	1	1	1
34	217240L	Limit Cover	1	1	1
35	400856	Spring Washer <M8>	4	4	4
36	408580	Hex. Recess Bolt <M8 × 1.25 × 16L>	4	4	4
37	209000N	Gearbox	1	1	
	209487N				1
38	402580	Gearbox Gasket	1	1	1
39	407472	Parallel Pin < Ø6 × Ø15 >	2	2	2
40	209488L	Gearbox Cover	1	1	1
41	400095	Spring Washer <M8>	9	9	9
42	408457	Hex. Recess Bolt <M8 × 1.25 × 90L>	9	9	9
43	402450	Electric Cover Gasket	1	1	1
44	300380L	Electric Cover	1	1	1
45	400856	Spring Washer <M8>	8	8	8
46	408580	Hex. Recess Bolt <M8 × 1.25 × 16L>	8	8	8
47	404510	O-Ring <P-25>	1	1	1
48	202181	Cable Fixing Plate	1	1	1
49	300801	Cable Fixing Plate	2	2	2
50	400094	Spring Washer <M8>	2	2	2
51	408465	Hex. Recess Bolt <M8 × 1.25 × 16L>	2	2	2

HOOK EXPLOSION

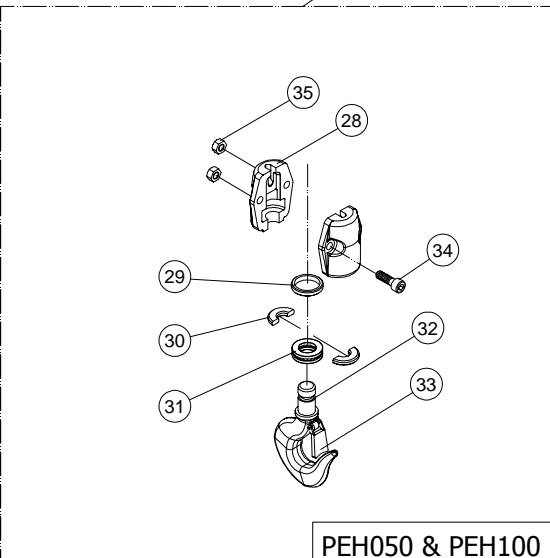
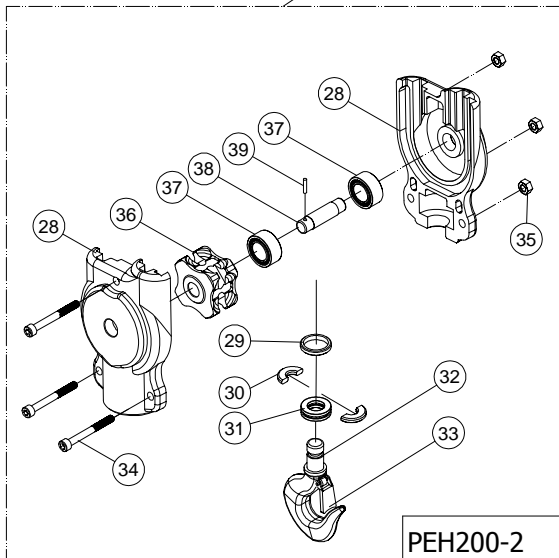
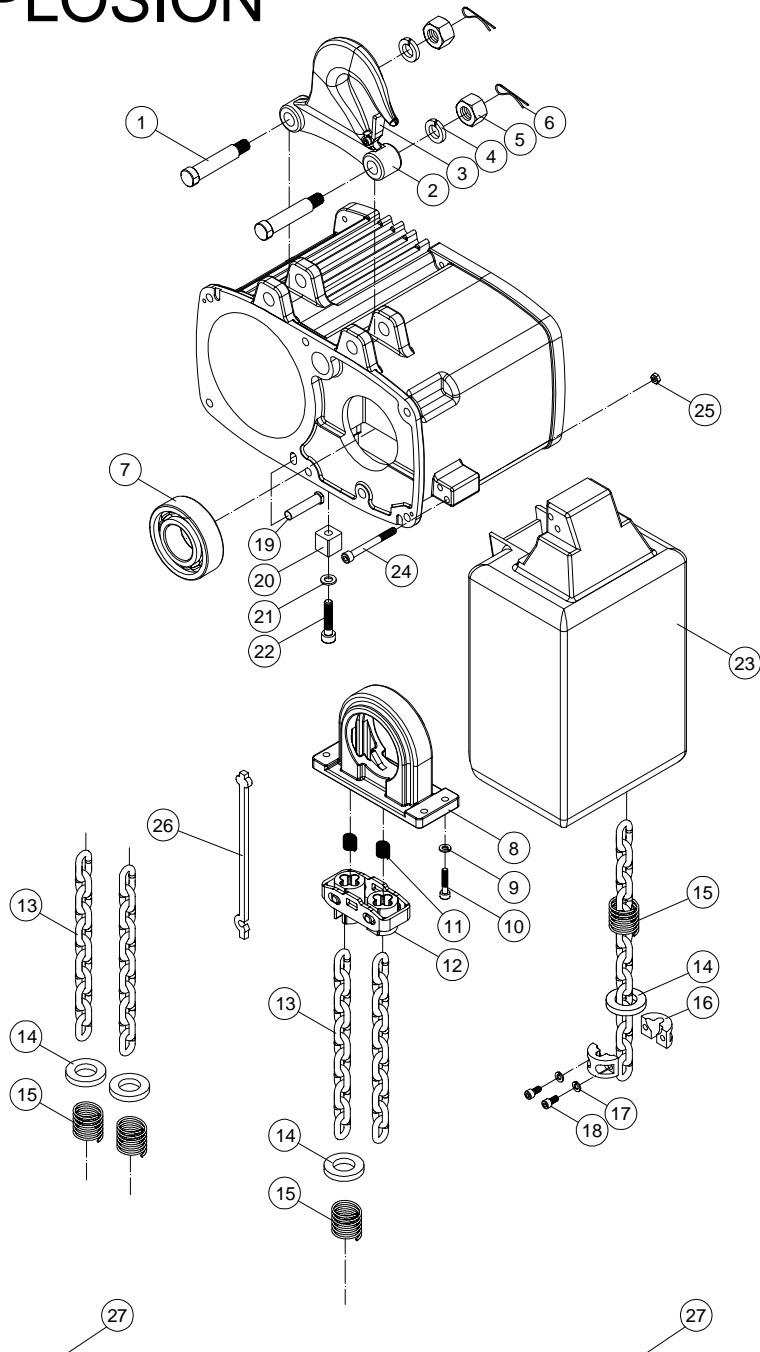

HOOK ASSEMBLY

NO.	PARTS CODE	DESCRIPTION	Q'TY REQ'D EACH UNIT		
			PEH050(NH)	PEH100(NH)	PEH200-2(NH)
1	201310	Lock Bolt <Ø14×83>	2	2	2
2	208812L	Top Hook Ass'y	1		
	200018L			1	1
3	400487	Safety Latch Ass'y	1	1	1
4	400097	Spring Washer <M12>	2	2	2
5	400084	Nut <M12×1.75>	2	2	2
6	400610	Cotter Pin < Ø3 × 30>	2	2	2
7	407851	Bearing <6306 ZZ>		1	
8	208860	Chain Regulator	1		
	209279			1	1
9	400094	Spring Washer <M6>	4	4	4
10	400006	Hex. Recess Bolt <M6x1.0x16>	4	4	4
11	408622	Spring	2		
	408640			2	2
12	262500	Guide Tube Ass'y	1		
	262576			1	1
13	408708	Chain < Ø6.3 × 19.1>	3.5M		
	408707	Chain <Ø7.1 × 20.2>		3.5M	7M
14	200310	Limit Stopper Ass'y	2	2	3
15	408502	Spring	2	2	3
16	200200	Chain Stopper	2	2	2
17	400094	Spring Washer <M6>	2	2	2
18	400007	Hex. Recess Bolt <M6 × 1.0 × 20>	2	2	2
19	201382	Chain Connecting Pin < Ø14 × 50>	1		
	201274	Chain Connecting Pin < Ø16 × 80>		1	1
20	201381	Fixed Block	1		
	201379			1	1
21	400854	Spring Washer <M5>	1		
	400094	Spring Washer <M6>		1	1
22	408329	Hex. Recess Bolt <M5 × 0.8 × 20>	1		
	400006	Hex. Recess Bolt <M6 × 1.0 × 16>		1	1

HOOK ASSEMBLY

NO.	PARTS CODE	DESCRIPTION	Q'TY REQ'D EACH UNIT		
			PEH050(NH)	PEH100(NH)	PEH200-2(NH)
23	201386	Chain Bucket <Ø6.3-2#>	1		
	208807	Chain Bucket <Ø7.1-3#>		1	1
24	408487	Hex. Recess Bolt <M5 × 0.8 × 80>	2		
	408470	Hex. Recess Bolt <M6 × 1.0 × 80>		2	2
25	400646	Nylon Nut <M5>	2		
	400087	Nylon Nut <M6>		2	2
26	400513	Substitute Chain <Ø6.3 × 19.1>	1		
	400511	Substitute Chain <Ø7.1 × 20.2>		1	1
27	200020L	Bottom Hook Cover Ass'y	1		
	201377L			1	
	200029L				1
28	200102L	Bottom Block Cover	1		
	207073L			1	
	207074L	Bottom Block Cover A			1
	207075L	Bottom Block Cover B			1
29	200131	End Spacer	1	1	
	200132				1
30	200127	Half Spacer	2	2	
	200128				2
31	400157	Thrust Bearing <2904>	1	1	
	400158	Thrust Bearing <2905>			1
32	209351L	Bottom Hook Ass'y	1		
	209352L			1	
	209353L				1
33	400487	Safety Latch Ass'y	1	1	
	400488				1
34	408340	Hex. Recess Bolt <M8 × 1.25 × 30>	2	2	
	408345	Hex. Recess Bolt <M8 × 1.25 × 35>			3
35	400088	Nylon Nut <M8 × 1.25>	2	2	3
36	200108	Sprocket	-	-	1
37	400171	Needle Bearing <HK25/26>	-	-	1
38	200114	Sprocket Axle	-	-	1
39	400212	Spring Pin < Ø5 × 16>	-	-	1

HOOK EXPLOSION

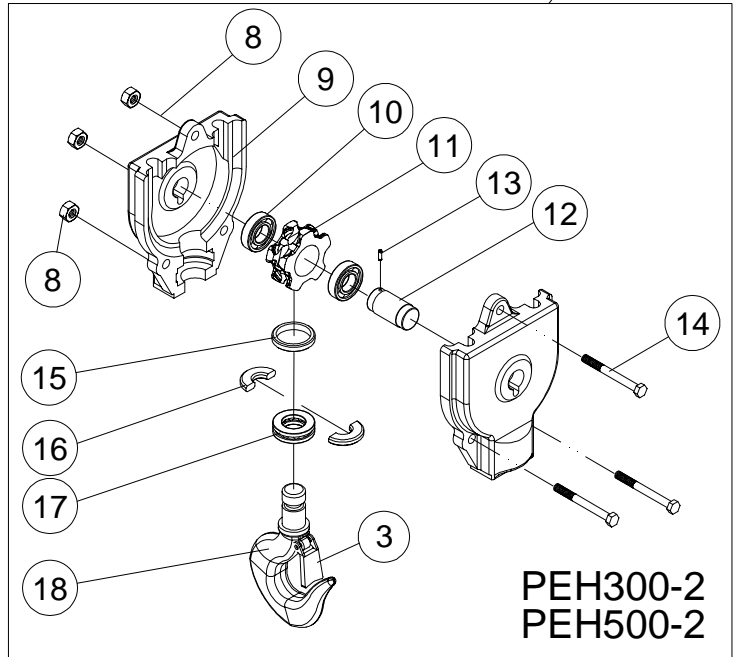
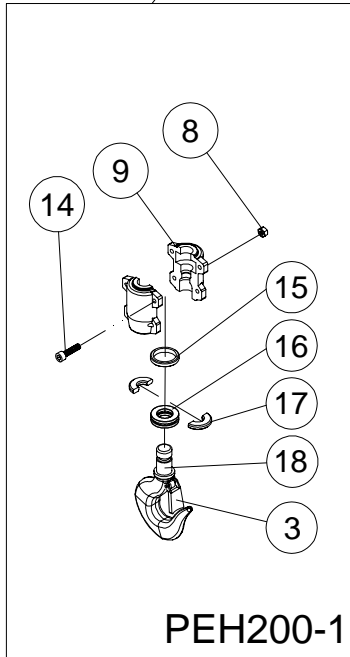
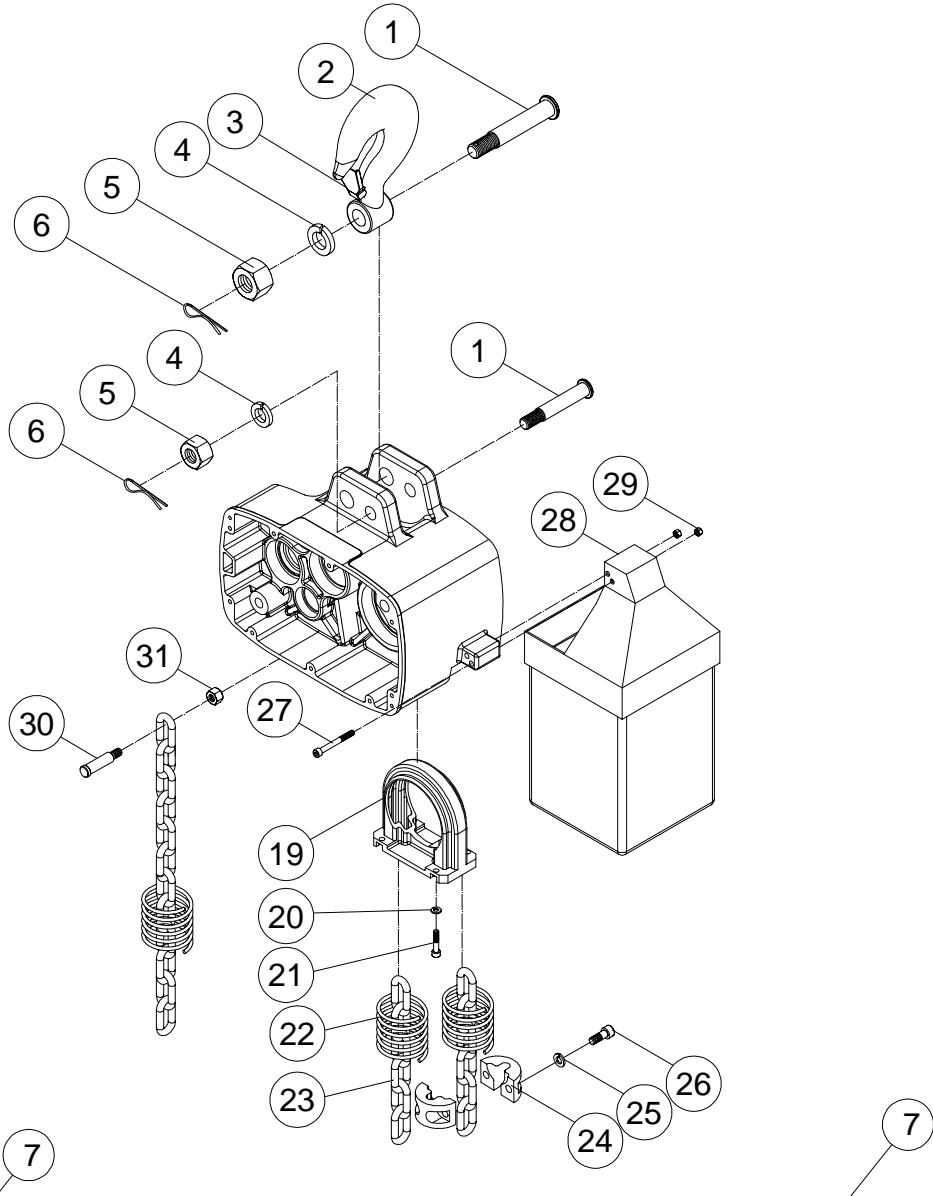

HOOK ASSEMBLY

NO.	PARTS CODE	DESCRIPTION	Q'TY REQ'D EACH UNIT		
			PEH200-1(NH)	PEH300-2(NH)	PEH500-2(NH)
1	268549	Top Hook Pin <Ø25 × 159L>	2	2	1
	200460	Top Hook Pin <Ø34 × 159L>			1
2	209346L	Top Hook Ass'y	1		
	209345L			1	
	209348L				1
3	400489	Safety Latch Ass'y	2	2	2
4	400098	Spring Washer <M16>	2	2	1
	400099	Spring Washer <M20>			1
5	400085	Lock Nut <M16 × 1.5>	2	2	1
	400086	Lock Nut <M20 × 2.0>			1
6	400603	Cotter Pin <3/32" × 1"L>	2	2	2
7	200759L	Bottom Hook Ass'y	1		
	200759L			1	
	200027L				1
8	400088	Lock Nut <M8 × 1.25>	4		
	400089	Lock Nut <M10 × 1.5>		3	3
9	200099L	Bottom Hook Housing	2		
	200100L			2	
	200101L				2
10	408052	Needle Bearing <TA 3020 Z>		2	
	400174	Needle Bearing <TA 4025 Z>			2
11	200170	Sprocket <Ø40 × 42L>		1	
	200111	Sprocket <Ø50 × 51L>			1
12	200813	Bottom Hook Idle Wheel Axle <Ø30 × 71L>		1	
	200116	Bottom Hook Idle Wheel Axle <Ø40 × 78L>			1
13	400212	Spring Pin <Ø5 × 16L>		1	1
14	400015	Hex. Recess Bolt <M8 × 1.25 × 40L>	4		
	400018	Hex. Recess Bolt <M10 × 1.5 × 40L>		3	
	400019	Hex. Recess Bolt <M10 × 1.5 × 45L>			3
15	200133	Bottom Hook Retaining Ring	1	1	
	200134				1

HOOK ASSEMBLY

NO.	PARTS CODE	DESCRIPTION	Q'TY REQ'D EACH UNIT		
			PEH200-1(NH)	PEH300-2(NH)	PEH500-2(NH)
16	200129	Bottom Hook Half Spacer	2	2	
	200130				2
17	400159	Thrust Bearing <51106>	1	1	
	400160	Thrust Bearing <51207>			1
18	209356L	Bottom Hook	1		
	209355L			1	
	209358L				1
19	209483	Chain Regulator	1	1	
	209120				1
20	400095	Spring Washer <M8>	4	4	4
21	400012	Hex. Recess Bolt <M8 × 1.25 × 20L>	4	4	4
22	400233	Limit Spring	2	3	
	400234				3
23	400543	Load Chain <Ø10.0>	7.6	7.6	
	400544	Load Chain <Ø11.2>			7.6
24	200201	Chain Stopper <Ø10>	2	2	
	200202	Chain Stopper <Ø11.2>			2
25	400095	Spring Washer <M8>	2	2	2
26	400014	Hex. Recess Bolt <M8 × 1.25 × 30L>	2	2	2
27	400427	Hex. Recess Bolt <M8 × 1.25 × 80L>	2	2	2
28	216910	Chain Bucket	1	1	1
29	400088	Nylon Nut < M8 × 1.25>	2	2	2
30	268552	Chain Connecting Pin<Ø19 × 86L>	-	1	
	203219	Chain Connecting Pin<Ø19 × 86L>			1
31	400091	Nylon Nut < M12 × 1.75>	-	1	1

GEAR BOX EXPLOSION

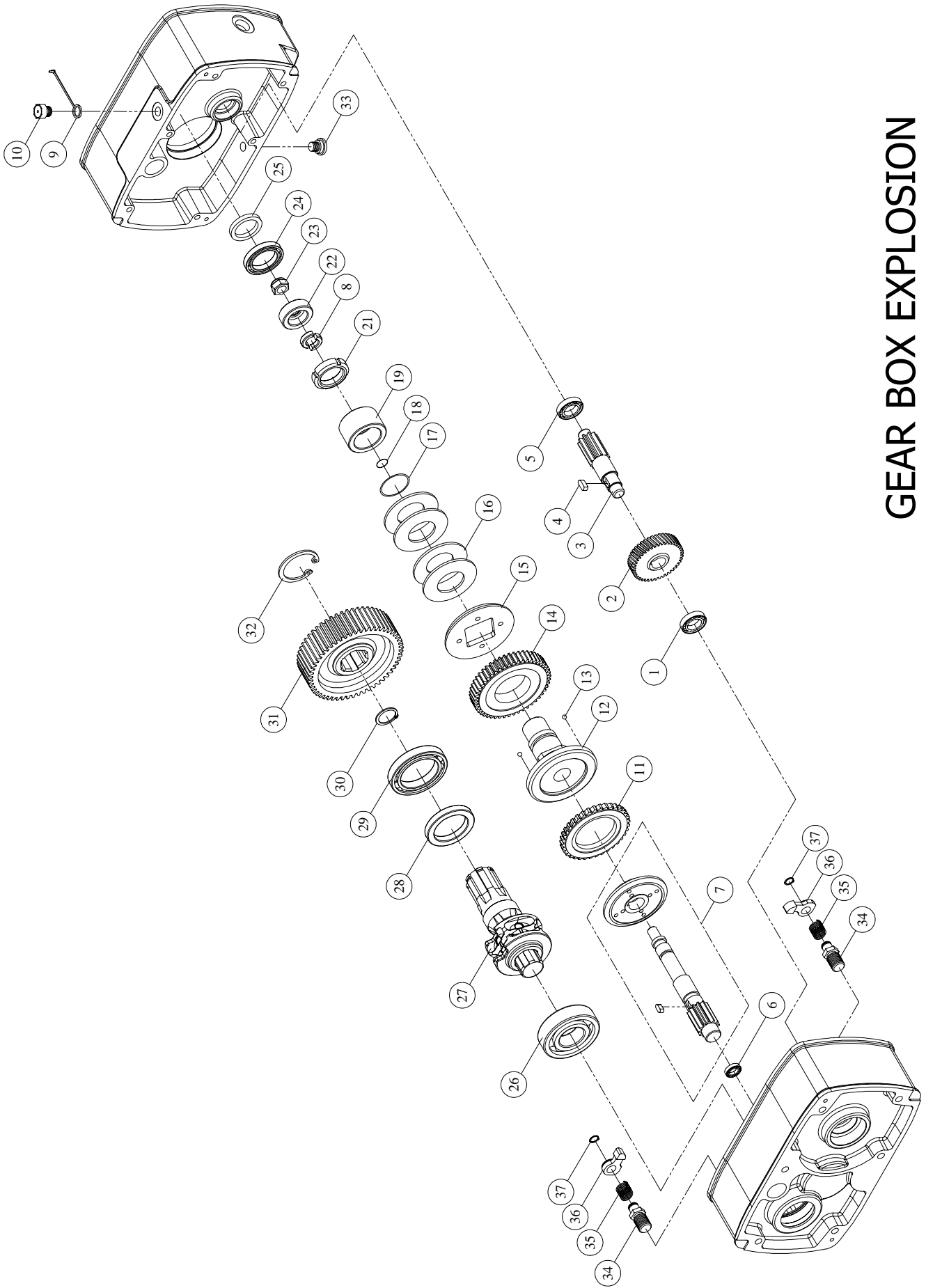

GEAR BOX ASSEMBLY

NO.	PARTS CODE	DESCRIPTION	Q'TY REQ'D EACH UNIT	
			PEH050(NH)	PEH100(NH) PEH200-2(NH)
1	407869	Bearing <6002 ZZ>	1	
	405711	Bearing <6202>		1
2	202190	2nd Gear <M1.25 × 50T × 14L>	1	
	222314	2nd Gear <M1.5 × 42T × 17L>		1
3	202191	3rd Gear <M2 × 12T × 88L>	1	
	202265	3rd Gear <M2 × 10T × 105L>		1
4	400962	Key <t6 × 6 × 12L>	1	
	400963	Key <t6 × 6 × 15L>		1
5	407869	Bearing <6002 ZZ>	1	
	405711	Bearing <6202>		1
6	400132	Bearing <6204>	1	
	400136	Bearing <6304>		1
7	268900	5th Gear Ass'y <M2 × 13T> 50HZ	1	
	222380	5th Gear Ass'y <M2.25 × 15T> 50HZ		1
8	200272	Load Brake Gear Spacer	2	
	200273			2
9	200927	Air Plug	1	1
10	200926	Hex. Oil Plug	1	1
11	208843	Ratchet Ass'y	1	
	209126			1
12	201280	Brake Bushing	1	
	209129			1
13	400289	Ball < Ø6>	3	3
14	202192	4th Gear Ass'y <M2 × 49T × 18>	1	
	222307	4th Gear Ass'y <M2 × 54T × 21>		1
15	209440	Brake Body <Ø90 × 7.6L>	1	
	209273	Brake Body <Ø101 × 7L>		1
16	400799	Disc Spring <Ø70 × Ø35.5 × 3t>	3	
	408643	Disc Spring <Ø80 × Ø36 × 3t>		4
17	404519	O-Ring <P-29>	1	1
18	404509	O-Ring <P-14>	1	
	404453	O-Ring <P-18>		1
19	209460	Disc Spring Bushing	1	
	209274			1

GEAR BOX ASSEMBLY

NO.	PARTS CODE	DESCRIPTION	Q'TY REQ'D EACH UNIT	
			PEH050(NH)	PEH100(NH) PEH200-2(NH)
21	406440	Nut <YSR M30 × 1.5P-RT>	1	
	406439	Nut <YSR M35 × 1.5P-RT>		1
22	209393	End Spacer <Ø40 × Ø14 × 13L>	1	
	209275	End Spacer <Ø45 × Ø14 × 13L>		1
23	400091	Lock Nut <M12 × 1.75>	1	1
24	405593	Bearing < 6910 ZZ >	1	
	405712	Bearing < 6912 >		1
25	404460	Oil Seal < Ø50 × Ø68 × 9t>	1	
	404534	Oil Seal < Ø60 × Ø80 × 8t>		1
26	400108	Bearing < 6006ZZ >	1	
	407851	Bearing < 6306 ZZ>		1
27	200007	Load Sheave <Ø68.5 × 144L>	1	
	209276	Load Sheave < Ø73 × 158.5L>		1
28	400187	Oil Seal < Ø35 × Ø50 × 8t>	1	
	404532	Oil Seal < Ø45 × Ø72 × 10t>		1
29	400108	Bearing < 6006ZZ >	1	
	407759	Bearing < 6208 >		1
30	400192	Retaining Ring <S-25>	1	
	404161	Retaining Ring <S-38>		1
31	202201	6th Gear <M2 × 42T>	1	50HZ
	222312	6th Gear <M2.25 × 52T>		50HZ
32	400906	Retaining Ring <R-55>	1	
	400202	Retaining Ring <R-80>		1
33	300523	Lubricant Drain Bolt	1	1
34	200440	Ratchet Pawl Pin	2	
	200410			1
35	400038	Ratchet Pawl Spring	2	
	200439			1
36	200415	Ratchet Pawl	2	
	200287			1
37	400907	Retaining Ring <S-11>	2	1

GEAR BOX EXPLOSION

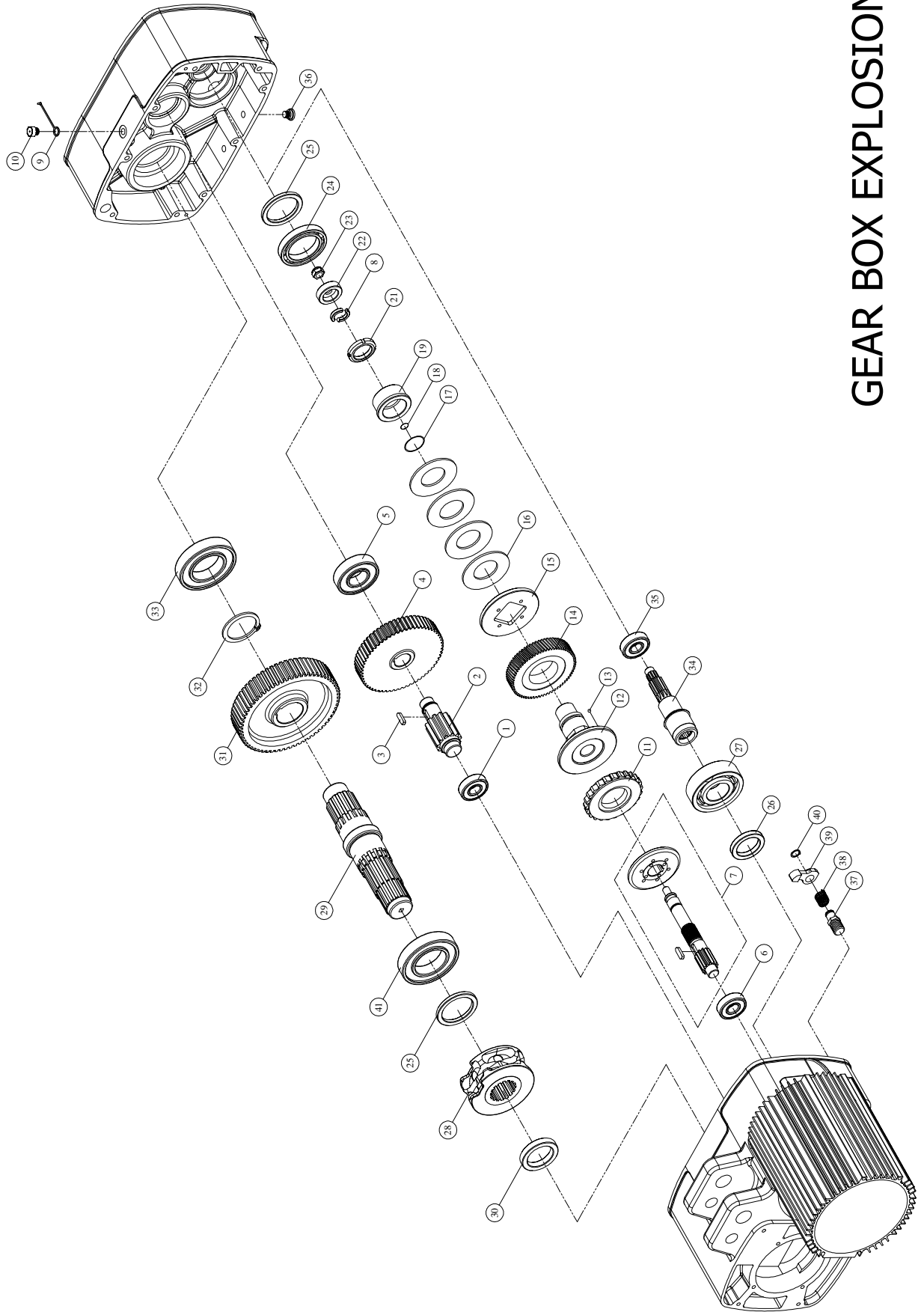

GEAR BOX ASSEMBLY

NO.	PARTS CODE	DESCRIPTION	Q'TY REQ'D EACH UNIT		
			PEH 200-1(NH)	PEH 300-2(NH)	PEH 500-2(NH)
1	400721	Bearing <6307 ZZ>	1	1	1
2	202158	5nd Gear <M3 × 15T × 149.5L>	1	1	1
3	405908	Key <t12 × 8 × 30L>	1	1	1
4	202169	4rd Gear <M2 × 73T × 32L>	1		
	202166	4rd Gear <M2 × 68T × 32L>		1	
	202157	4rd Gear <M2 × 77T × 32L>			1
5	405711	Bearing <NF306>	1	1	1
6	400136	Bearing <6304>	1	1	1
7	269100	3th Gear Ass'y <M2 × 19T × 210>	1		
	269315	3th Gear Ass'y <M2 × 24T × 210>		1	
	269317	3th Gear Ass'y <M2 × 15T × 210>			1
8	200273	Load Brake Gear Spacer	2	2	2
9	200927	Air Plug	1	1	1
10	200926	Hex. Oil Plug	1	1	1
11	208999	Ratchet Ass'y	1	1	1
12	209284	Brake Bushing	1	1	1
13	400522	Ball < Ø8>	3	3	3
14	202160	2th Gear Ass'y <M1.75 × 68T × 24>	1	1	1
15	209330	Brake Body <Ø112 × 8>	1	1	1
16	408590	Disc Spring <Ø90 × Ø45 × 3.5t>	4	4	4
17	404433	O-Ring <P-38>	1	1	1
18	404453	O-Ring <P-18>	1	1	1
19	209340	Disc Spring Bushing	1	1	1
21	406439	Nut <YSR M35 × 1.5P-RT>	1	1	1
22	268480	End Spacer <Ø45 × Ø14 × 13L>	1	1	1
23	400091	Lock Nut <M12 × 1.75>	1	1	1
24	405712	Bearing < 6912 >	1	1	1
25	404472	Oil Seal <Ø60 × Ø78 × 7t>	2	2	2
26	400944	Oil Seal <Ø45 × Ø60 × 8t>	1	1	1
27	400140	Bearing < 6009 ZZ>	1	1	1

ELECTRIC ASSEMBLY

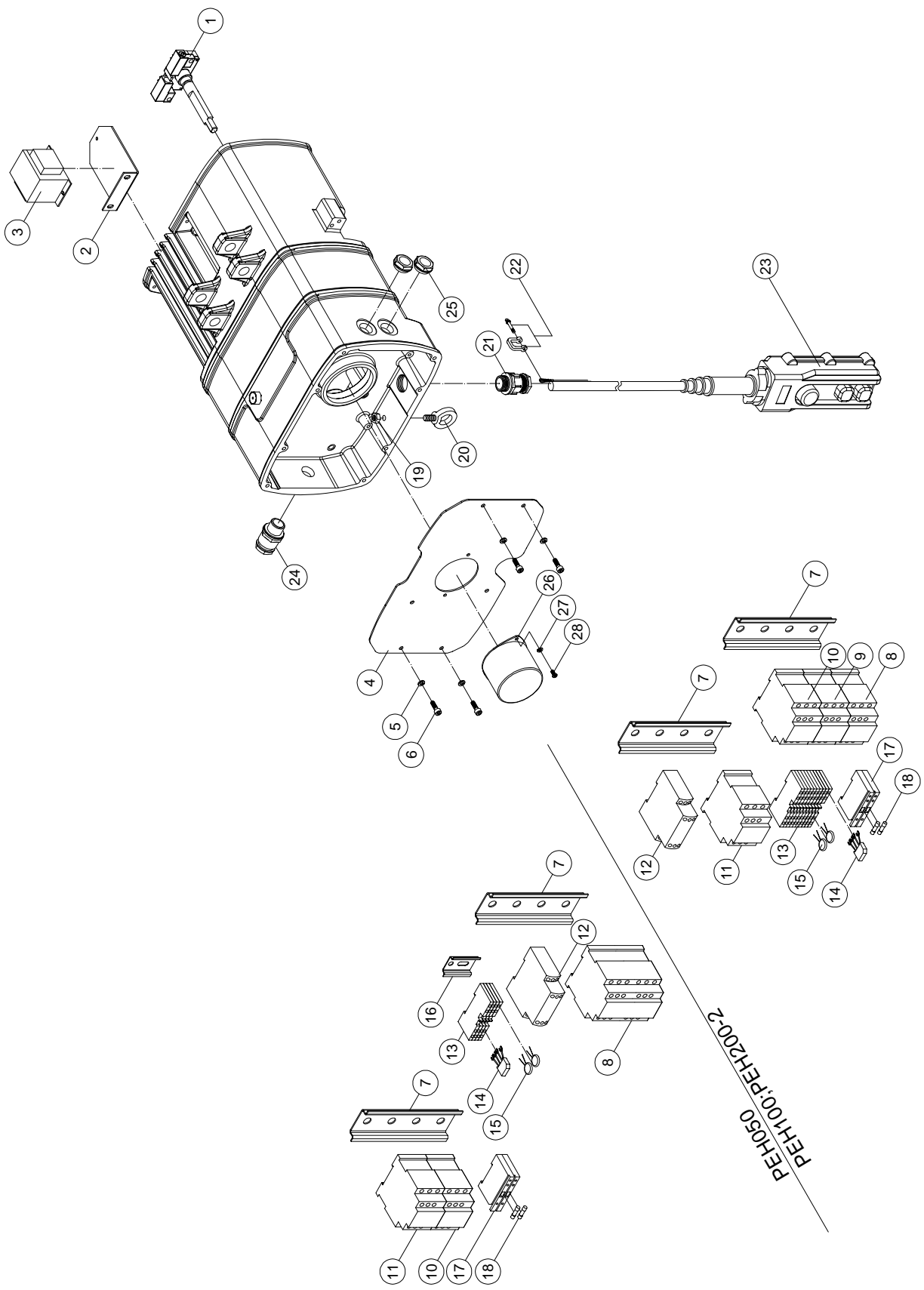

ELECTRIC ASSEMBLY

NO.	PARTS CODE	DESCRIPTION	Q'TY REQ'D EACH UNIT			
			PEH050	PEH050NH	PEH100 PEH200-2	PEH100NH PEH200-2NH
1	302500	Upper & Lower Limit Switch	1	1		
	302337				1	1
2	300628	Transformer Bracket	1	1		
	300630				1	1
3	303757	Transformer PS-102	1	1		
	303054	Transformer PS-16207N			1	1
4	300760	Electric Bracket	1	1		
	300859				1	1
5	400093	Spring Washer <M5>			4	4
6	408361	Hex. Recess Bolt <M5 × 0.8 × 10L>			4	4
7	300092	Contactor Rail	2	2		
	300091				2	2
8	300065	Contactor < 24V 4A LC2-K09004-B7>	1	1		
	301106	Contactor <24V 3A1a1b LC1-D12-B7>			1	1
9	301106	Contactor <24V 3A1a1b LC1-D12-B7>	-	-	1	1
10	300066	Contactor < 24V 2A2B LC1-K09008-B7>	1	-		
	301106	Contactor <24V 3A1a1b LC1-D12-B7>			1	1
11	300064	Contactor < 24V 3A1b LC1-K0901-B7>	1	1		
	300035	Contactor <24V 2A2B LC1-D128-B7>			1	-
12	302376	Phase Sequence Protector <RM17- TG00>	1	1	1	1
13	302342	Terminal Block (PT 2,5-QUATTRO)	4	4	10	10
14	300150	Rectifier KBC10	1	1	1	1
15	300148	Varistor 14K471U	2	2	2	2
16	300078	Contactor Rail	1	1	-	-
17	300995	Fuse Holder	2	2	2	2
18	300993	Fuse	2	2	2	2
19	400080	Nut <M6 × 1.0>	1	1	1	1
20	404803	Eye Bolt <M6 × 1.0>	1	1	1	1
21	400941	Cable Gland <M25-18>	1	1	1	1
22	400297	Shackle <3/16" >	1	1	1	1
23	300484	Push Button Switch(Dual speed)	1	-	1	-
	300459	Push Button Switch(Indirect)	-	1	-	1

ELECTRIC ASSEMBLY

NO.	PARTS CODE	DESCRIPTION	Q'TY REQ'D EACH UNIT			
			PEH050	PEH050NH	PEH100 PEH200-2	PEH100NH PEH200-2NH
24	400222	Cable Gland <M20-13>	1	1	1	1
25	408436	Cable Gland <SPG-M20B M20×1.5>	2	2	2	2
26	262709	Cover	1	1		
	272862				1	1
27	400092	Spring Washer <M4>	2	2	2	2
28	408394	Cross Headed Screw <M4×0.7×6L>	2	2	2	2

ELECTRIC ASSEMBLY

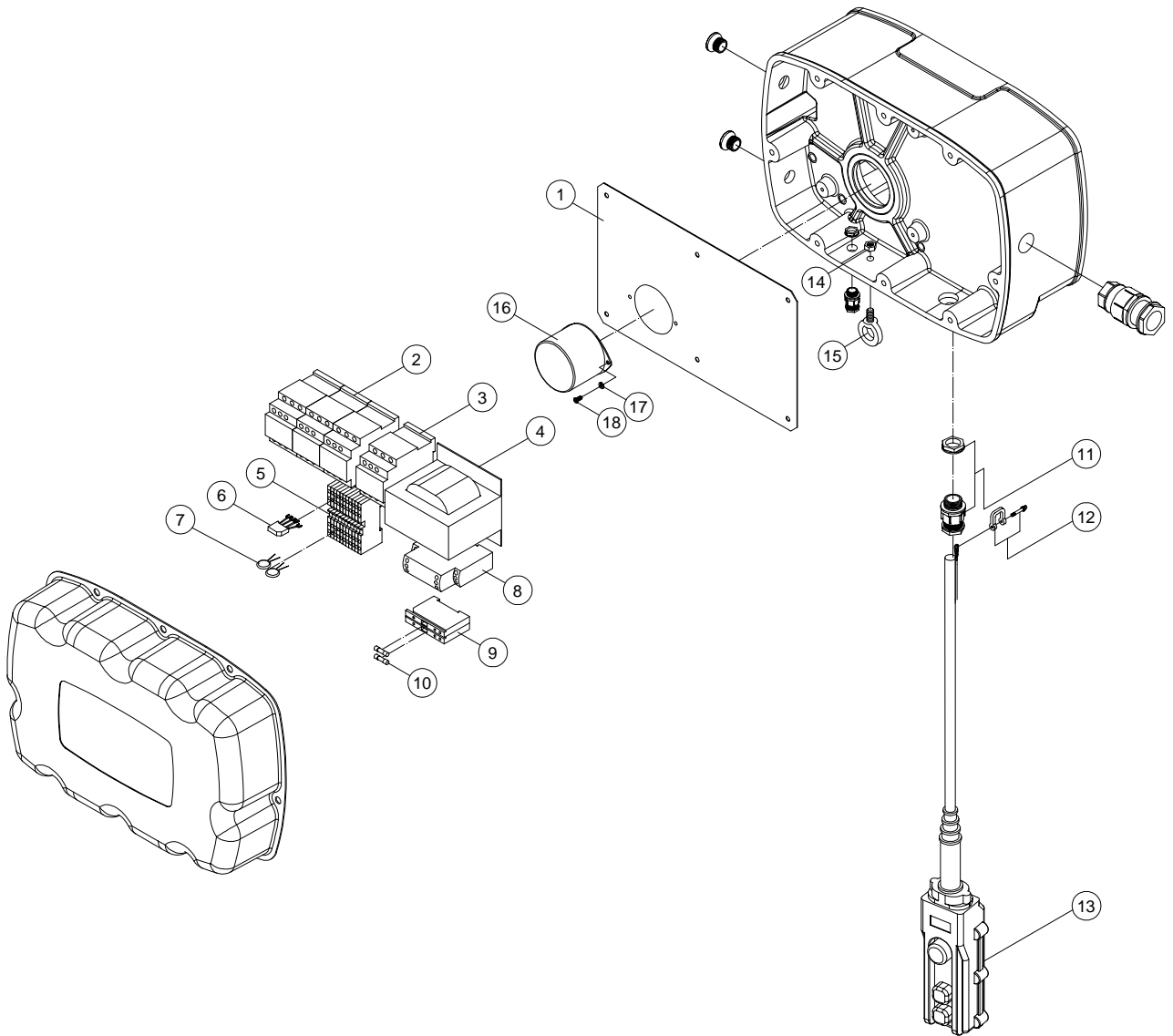

ELECTRIC ASSEMBLY

NO.	PARTS CODE	DESCRIPTION	Q'TY REQ'D EACH UNIT					
			PEH 200-1	PEH 200-1NH	PEH 300-2	PEH 300-2NH	PEH 500-2	PEH 500-2NH
1	300089	Electric Bracket	1	1	1	1	1	1
2	301114	Contactora < 24V 3A1a1b LC1-D25-B7>	3	3	3	3	3	3
3	300040	Contactora <24V 2A2B LC1-D258-B7>	1	-	1	-	1	-
4	301330	Transformer PS-16212N	1	1	1	1	1	1
5	302342	Terminal Block (PT 2,5-QUATTRO)	15	15	15	15	15	15
6	300150	Rectifier KBC10	1	1	1	1	1	1
7	300148	Varistor 14K471U	2	2	2	2	2	2
8	302376	Phase Sequence Protector <RM17-TG00>	1	1	1	1	1	1
9	300995	Fuse Holder	2	2	2	2	2	2
10	300999	Fuse	2	2	2	2	2	2
11	400941	Cable Gland <M25-18>	1	1	1	1	1	1
12	400297	Shackle <3/16">	1	1	1	1	1	1
13	300484	Push Button Switch(Dual speed)	1	-	1	-	1	-
	300459	Push Button Switch(Indirect)	-	1	-	1	-	1
14	400081	Nut <M8× 1.25>	1	1	1	1	1	1
15	400217	Eye Bolt <M8× 1.25>	1	1	1	1	1	1
16	272862	Cover	1	1	1	1	1	1
17	400092	Spring Washer <M4>	2	2	2	2	2	2
18	408394	Cross Headed Screw <M4× 0.7× 6L>	2	2	2	2	2	2

EC Declaration of Conformity



PACIFIC HOISTS PTY LTD.,
24 Foundry Rd., Seven Hills, NSW 2147, Australia.
Tel: +61 2 8825 6900 Fax: +61 2 8825 6999

According to the following EU Directives:

- Machinery Directive: 2006/42/EC
- Low Voltage Directive: 2006/95/EC

We, PACIFIC HOISTS PTY LTD.,
declare that the machines mentioned hereafter:

☉Product: Electric chain hoist

Model No.:

PEH025,PEH052,PEH050,PEH100,PEH200-2,PEH200-1,PEH300-2,PEH500-2,
PEH025NH,PEH050NH,PEH100NH,PEH200-2NH,PEH200-1NH,PEH300-2NH,
PEH500-2NH

☉Product : Electric Motorized:

Model No. :

PET050,PET055,PET100,PET105,PET200,PET205,PET210, PET0215, PET310,
PET315, PET510, PET315

☉Functions:

Lifting equipment

They are designed and manufactured in compliance with the essential health and safety requirements of the Machinery Directive and Low Voltage Directive.

They are based on the following European harmonized standards:

- EN ISO 12100:2010, Safety of machinery - Basic concepts, general principles for design Part 1: Basic terminology, methodology.
- EN 14492-2:2019, Cranes - Power driven winches and hoists - Part 2: Power driven hoists.
- EN 60204-32:2008, Safety of machinery - Electrical equipment of machines - Part 32 Requirements for hoisting machines
- FEM 9.511 (Classification of mechanisms)
- FEM 9.681 (Selection of travel motors)
- FEM 9.682 (Selection of lifting motors)
- FEM 1.001 (Rules for the design of hoisting appliances)

Representative : *STEVE PURVES*

Title: *DIRECTOR*

Place / Date : Australia / Mar. 17, 2022.