

VITAL®

V Lever VR₂

Operating Instructions

Before operating this product, please read the instructions carefully to ensure correct use, and keep it in a safe place for later reference.



— Table of Contents —

Eight Important Safety Rules:.....	2
Preparations before Use	3
Normal State of Use.....	4
Start Idling	4
Stop Idling	4
After Use	4
Parts Diagram	5
How to Disassemble and Reassemble the Lever	6
Inspection and Maintenance	6
Specifications	7
VR2-60 (6.3ton) Bottom Hook Parts Diagram	8
Criteria for Use	9
Inspection Standard	9
Inspection Guideline	10 • 11
MEMO	12 • 13

Eight Important Safety Rules:



Danger

The lever hoist handles heavy objects. Neglect of safety precautions can lead to damages or death. Be extremely careful.

- ① Don't lift a load heavier than the specified tons. Don't try to make the lever longer.

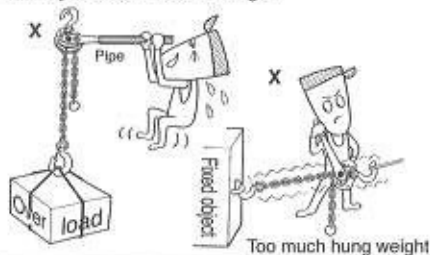

- ② Don't use parts which were deformed by overloading.



- ③ Don't put the upper and lower hooks out of alignment with the chain. Should be in a straight line.

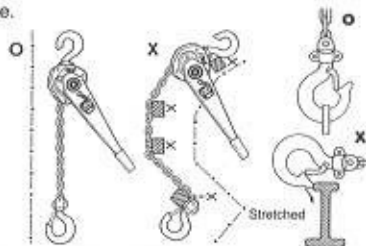

- ④ Don't use your chain block in ways that produce shock pressures.



- ⑤ Don't use a chain with a twist or kink.

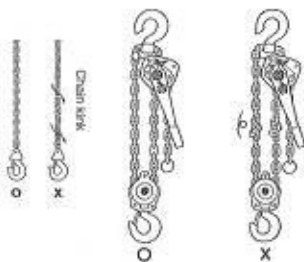

- ⑥ Don't wind or unwind too much.



- ⑦ Don't forget to make sure that the holder pawl perfectly holds the holder plate.

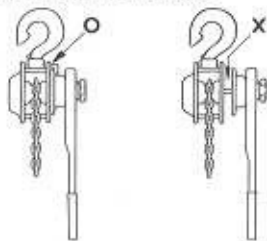

- ⑧ Don't try to suspend a load with two blocks.



Preparations before Use

1. Lightly oil the chain. Ease the movement of the links, and ensure that there are no kinks or twists in the chain.

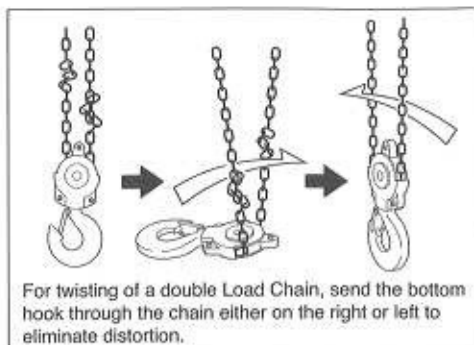
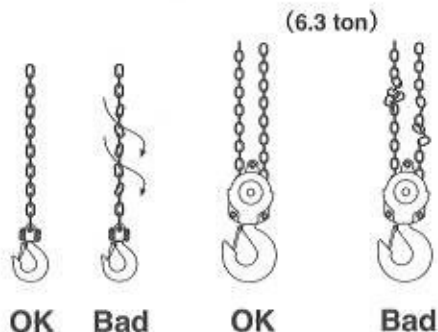

2. Set up the hook and chain in a straight line, so there is not too much strain (see caution note 3 on the previous page.)

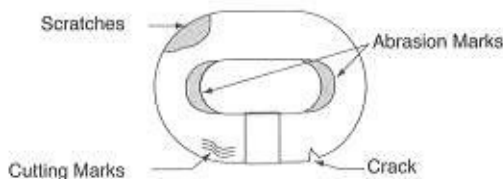

Normal State of Use

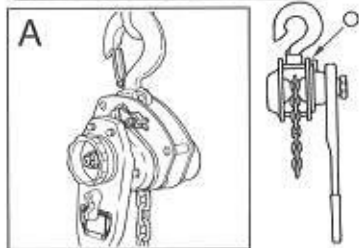

Before use, check that the retaining pawl perfectly engages the retaining plate from outside.

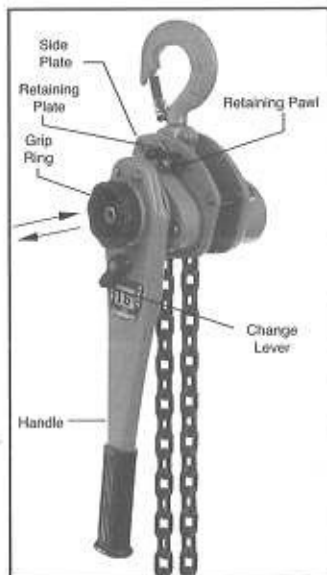

3. How to adjust the chain length

Start Idling

(Caution before use) Do not operate the hoist with a load suspended or the dead weight of elongated chain carried on the side of the bottom hook.

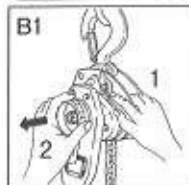

- B1. 1. While your finger presses the retaining pawl as far as possible to the bottom,
2. Pull the grip-ring outward.

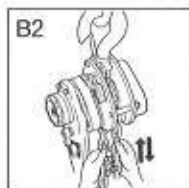

- B2. Stop pressing the retaining pawl with your finger, so the retaining pawl slides between the side plate and the retaining plate. By pulling, the chain can now be freely adjusted up or down.

Stop Idling

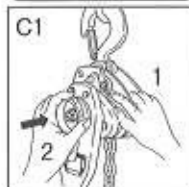

- C1. 1. While pressing the retaining pawl as far as possible towards the bottom,
2. Lightly push the grip ring inward.

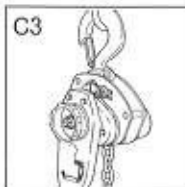

- C3. Check that the retaining pawl has returned from the outside of the plate, to its original position where it holds the retaining plate. It will then return to the "normal state of use" as indicated in A.

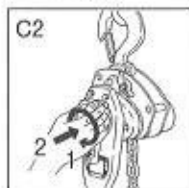

- C2. 1. Next, grip the grip-ring, rotate it clockwise a little, and
2. Push it in. The retaining pawl will automatically set itself outside the retaining plate.

- C2. Caution: If you push the grip ring too hard, the gear may chip or break. If it does not set properly, try again.

- Caution 1. Pull a small load up and down a few times to see that the brake will not slip.
Caution 2. If there is too much rotational play in the grip ring, adjust the brake as shown in inspection item 5 on the next page.
Caution 3. Select the lifting height of the lever used, to suit the pulling force of the handle. Select a lever having the proper rating according to the pulling force of the handle.

After Use

- ① Don't leave the lever idling (See "Stop Idling" 3d3 on previous page)
- ② Wipe dirt and water off and apply oil to the chain, the revolving parts of the hook, the retaining pawl shaft, etc.
- ③ To store the lever, hang it in a dry place.

Parts List (VR2)

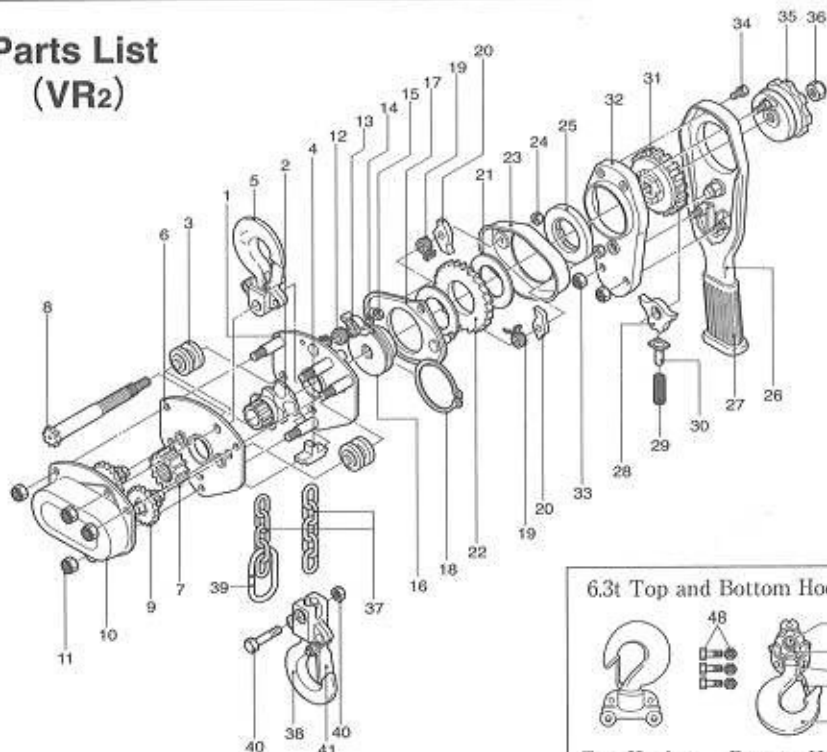

6.3t Top and Bottom Hooks

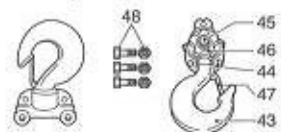

Top Hooks

Bottom Hooks

No.	Description	Parts No.	Quantity	No.	Description	Parts No.	Quantity
1	Side Plate Set (1)	L101a	1	22	Ratchet Gear	L303	1
2	Load Sheave	L203	1	23	Brake Cover	L105	1
3	Load Chain Guide	L109	2	24	Brake Cover Nut	L912	2
4	Chain Stripper	L110	1	25	Push Ring	L313	1
5	Top Hook Set	L701a	1	26	Lever Unit Set	L414a	1
6	Side Plate Set (2)	L102a	1	27	Grip	L430	1
7	G1 Gear	L206	1	28	Change Pawl	LNA402-08	1
8	Pinion	LV220	1	29	Push Spring	L405-A	1
9	G2.3 Gear Set	L207a	2	30	Push Pin	L404-A	1
10	Gear Cover Set	L108a	1	31	Change Gear	L427	1
11	Gear Cover Nut	L911	4	32	Lever Cover Set	L417a	1
12	Retaining Spring	L425	1	33	Lever Cover Nut	L913-A	2
13	Retaining Pawl	L424	1	34	Lever Bolt	L419-A	2
14	Retaining Washer	L423	1	35	Grip Ring	L428	1
15	Retaining Nut	L912	1	36	Pinion Nut	NS-10	1
16	Hub	LV314	1	37	Load Chain	L820	1
17	Retaining Plate Set	L422a	1	38	Bottom Hook Set	L709a	1
18	Snap Link for Hub	L421	1	39	End Ring	L746	1
19	Brake Spring	L305	2	40	Load Chain Bolt Set	L705a	1
20	Brake Pawl	LT304	2	41	1 Set of Safety Clasp	L740a	1
21	Brake Disc	L302	2				
6.3t Bottom Hook Parts							
43	Hook	L701-60	1	46	Idle Sheave	L725-60	1
44	Frame	L721-60	2	47	1 Set of Safety Clasp	L740a-60	3
45	Axle	L726-60	1	48	Frame Bolt Nut	L922a-60	3

How to Disassemble and Reassemble the Lever

- ① How to remove the chain: Remove the end, and while it is idling, slip the chain out (3d2 on previous page)
- ② Disassembly of the handle and brake: Disassemble starting from the right of the Parts Diagram.
- ③ Replacement of gear and 1 set of top hooks, and disassembly of central part: Disassemble starting from the left of the Parts Diagram.
- ④ Reassembly: Assemble in the order of the numbers in the Parts Diagram.

Inspection and Maintenance

If there are deformations (elongation, scratch, wear, crack, bend, etc.), you must replace those parts.

- ① Check that the chain, end and bottom hook are not deformed, by disassembling and assembling the lever as described above.
In Disassembly 1, check to see if the chain, end and bottom hook are not deformed.
- ② Check that the handle, grip ring, push ring, brake disc, retaining plate, hub, etc. are not deformed or damaged, by disassembling and assembling the lever as described above.
Also check that the retaining plate and retaining pawl do not rattle while it is idling.
- ③ Check that the gear cover, gear, side plate 1, top hook, hook pin, guide, load sheave, chain stripper and side plate 2 are not deformed and do not rattle.
- ④ Before assembly, wash all parts well with cleaning oil, etc.
Apply grease (lithium series No. 2 viscosity) to the rotating parts.

How to engage gears

● 0.8t and 1t

Engage gears so the teeth on the centerline of two marks (※) in the spline section of the second gear face each other, inner teeth to inner teeth, across the pinion (part no. 8).

● 1.6t

Gears can be engaged anywhere.

● 3.2t and 6.0t

Engage gears so the carved seals (←) on the surface of the second gear face each other, inner teeth to outer teeth, across the pinion.

- ① LV220
- ② L207
- ③ L208
- ④ L206

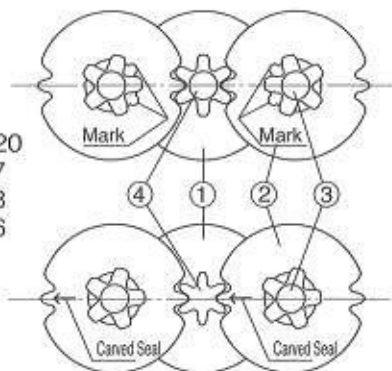

- ⑤ How to adjust the brake:

First, disconnect the grip ring (Parts Diagram no. 35).

Move the change lever to the neutral position, and pull the chain with hook strongly by hand downwards, to set the brake in a tightly engaged position.

Next, set the protruding portion of the grip ring (grip ring is also marked □) so it aligns a little to the left of the □ mark on the change gear.

How to adjust the brake: Disconnect the grip ring, and with the change lever in central position, pull the chain carrying the hook strongly with a hand in the lowering direction, so the brake is set in tightly engaged position. Then, fit the grip ring so its projection (marked ◻) is aligned with the ◻ mark of the change gear.

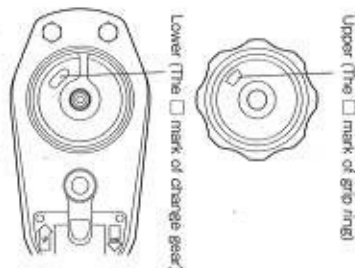

Specifications

(The number is subject to change.)

Abbreviation			VR ₂ -08	VR ₂ -10	VR ₂ -15	VR ₂ -30	VR ₂ -60
Load	Rating	(t)	0.8	1	1.6	3.2	6.3
Standard	Lifting	Height (m)	1.5	1.5	1.5	1.5	1.5
Empty	Weight	(kg)	6.9	7.1	9.7	16.3	26.7
Shortest Distance between Hooks			295	310	335	405	550
Attraction	Force in Hand	(kgf)	15	20	18	38	39
		(N)	147	196	177	373	382
Chain	Diameter	(mm)	6.3	6.3	7.1	9.0	9.0
Dimension	a	(mm)	148	148	163	191	191
	b	(mm)	128	128	148	181	244
	c	(mm)	295	310	325	395	550
	d	(mm)	256	256	368	368	368
	e	(mm)	20	22	27	37.5	49
	f	(mm)	14	16	19.5	27	36
	g	(mm)	27	30	34	43	47
	h	(mm)	52	52	63.5	83	83
	i	(mm)	96	96	99.5	108	108
	j	(mm)	39	39	46.5	54.5	68
	k	(mm)	89	89	101.5	126.5	176
	m	(mm)	36	41	47	56	63

•Various Lifting heights can be provided, if you request.

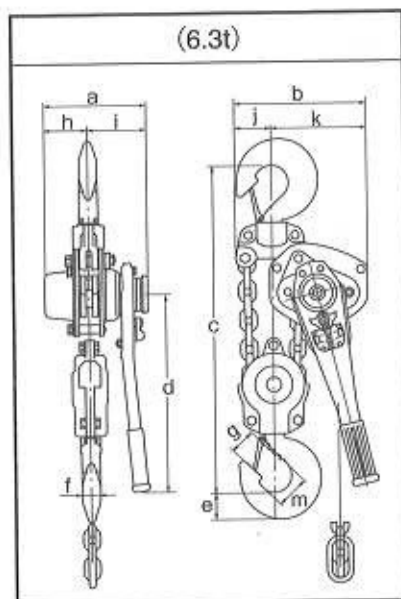
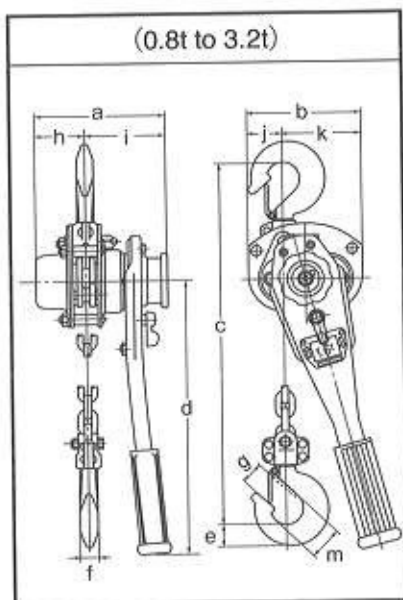

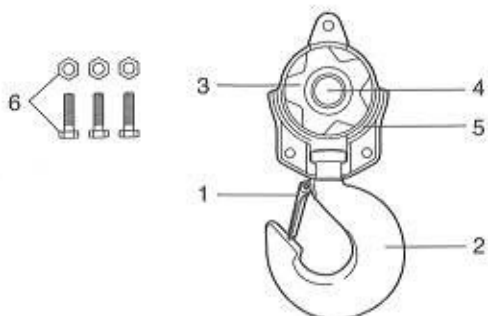

<V Lever VR2-60 (6.3ton) Bottom Hook Parts Diagram>



	Part No.	Part Name	Quantity
1	L740a-60	1 Set of Safety Clasps	1
2	L701-60	Hook only	1
3	L725-60	Idle Sheave	1
4	L726-60	Axle	1
5	L721-60	Frame	2
6	L922a-60	Frame Bolt Nut	3
	L709a-60	1 Set of Bottom Hooks	1

Criteria for Use

Precautions when Using V Lever

 Danger	1	Do not use it if the load rating on name plate cannot be read.
	2	Do not apply load that is more than the load rating, unless for inspections.
	3	Do not use load chain other than our product.
	4	Do not apply an abrupt load during operation
	5	Do not use the lever hoist for which lifting height is insufficient
	6	Do not use top hook or bottom hook that has no safety clasp or without effect of safety clasp.
	7	Do not use damaged or deformed top hook or bottom hook
	8	When the load is hung on the hook, hang at the position on the extended line of hook axis. Do not hang the load at the tip of hook.
	9	Do not use chain block in a way that the hook or main unit act as a supporting point.
	10	Do not use the lever without end ring.
	11	Do not use damaged or deformed load chain.
	12	Do not make load chain loop around the load.
	13	Do not make load chain touch against the corner of steel sheet, etc.
	14	Load chain must not be grounded during welding operation.
	15	Do not join load chain by welding.
	16	Do not extend the lever, using pipe, etc.
	17	Do not operate by foot.
	18	Do not wind or unwind too far.
	19	Do not step in under suspended load.
	20	Do not operate while you are on a suspended load.
	21	Do not idle when the load is hooked.
	22	Do not leave a load suspended.
	23	Make sure load chain is not twisted or kinked before use. Do not use lever hoist in water.
	24	Use within a range of -40°C to +60°C (maximum humidity of 100%).
	25	Do not alter products or parts.
	26	Do not throw or drag lever hoist.
 Caution	27	Do a daily checkup before use. Also do periodic checks (*1).
	28	When attraction force becomes abnormally strong during operation, immediately stop operation. Do not use a lever hoist for which attraction force became stronger than usual.
	29	Lubricate load chain before use.
	30	Lubricate gear, shaft bearing, and worn down places, before use.
	31	When it is not used for a long period of time, store lever hoist, taking action to prevent rust and keep out dust.
	32	When lever hoist is used for special purposes, please contact our company.

(*1) Do a periodic check every 6 months or annually, depending on frequency of use.

Inspection Standard

Precautions when inspecting V Lever

1	Inspection item, method and standard for daily inspection are based on "Guideline of Inspection" For high frequency use, or if used in special conditions, check various items in addition to inspection items.
2	Do periodic inspections based on "Guideline of Inspection"
3	If a lever hoist was repaired, check the product in accordance with periodic inspection items of "Guideline of Inspection" after repair, and check that the product works normally under loaded condition.
4	Always use our genuine parts for replacement parts.

Operational Load in Operational Test provided in JIS B 8819 is as follows.

Net Rated Load	0.8t	1t	1.6t	3.2t	6.3t
Operational Load	1.2t	1.5t	2.4t	4.8t	7.9t

(These loads are for testing. Do not use these loads for actual work)

Guideline of Inspection

Type of Inspection		Inspection Item	Inspection Method	Inspection Standard
Daily Inspection	Periodic Inspection			

<Display>

<input type="radio"/>	<input type="radio"/>	Display (Name Plate)	Visual Inspection	Presence/absence of display (Name Plate)
	<input type="radio"/>	Load Chain Classification		Check load chain classification

<Operation>

<input type="radio"/>	<input type="radio"/>	Winding / Unwinding Function	Lifting and Lowering	Brake device should tick-lack during winding. There must be no abnormality during unwinding.
<input type="radio"/>	<input type="radio"/>	Winding/Returning Switching Unit	Operation	Must actuate smoothly.
<input type="radio"/>	<input type="radio"/>	Idling Function	Operation	Must idle smoothly while not loaded.

<Hook>

<input type="radio"/>	<input type="radio"/>	Opening of Hook	Visual Inspection for Daily Inspection Measurement for Periodic Inspection	No deformation compared to standard dimensions. (Major Dimension Table shall be prepared prior to use.)
<input type="radio"/>	<input type="radio"/>	Deformation	Visual Inspection	No bending or distortion.
<input type="radio"/>	<input type="radio"/>	Deformation in Shank section	Visual Inspection for Daily Inspection Measurement for Periodic Inspection	No conspicuous gap between metal hook and shank section.
<input type="radio"/>	<input type="radio"/>	Abrasion and Corrosion		No conspicuous abrasion or corrosion.
<input type="radio"/>	<input type="radio"/>	Scratch or Harmful Defects	Visual Inspection	No crack or other harmful defects.
<input type="radio"/>	<input type="radio"/>	Safety Clasp	Visual Inspection Operation	No conspicuous abrasion or deformation. It must function normally.

<Load Chain>

<input type="radio"/>	<input type="radio"/>	Pitch Elongation	Visual Inspection for Daily Inspection Measurement for Periodic Inspection	Do not use chain elongated even in 1 link or 5% or more. (Standard dimension shall be prepared prior to use.)
<input type="radio"/>	<input type="radio"/>	Abrasion		Do not use chains abraded 10% or more of the diameter.
<input type="radio"/>	<input type="radio"/>	Deformation	Visual Inspection	No deformation.
<input type="radio"/>	<input type="radio"/>	Scratch or Harmful Defects		No crack or other harmful defects.
<input type="radio"/>	<input type="radio"/>	Corrosion		No conspicuous rust.

Guideline of Inspection

Type of Inspection		Inspection Item	Inspection Method	Inspection Standard
Daily Inspection	Periodic Inspection			

< Main Unit >

<input type="radio"/>	<input type="radio"/>	1-2 Set of Side Plate	Visual Inspection	No deformation or conspicuous corrosion.
<input type="radio"/>	<input type="radio"/>	Retaining Plate assembly		
<input type="radio"/>	<input type="radio"/>	Brake Cover		
<input type="radio"/>	<input type="radio"/>	Gear Cover		
<input type="radio"/>	<input type="radio"/>	Nut for each section, rivet, etc.		Check that there is no separation of nuts or rivets, etc. in places visible outside in daily inspection, and no loosening.
	<input type="radio"/>	1st Gear, 2nd and 3rd Gear Set	Visual Inspection or Measurement after Disassembly	Check that there is no abnormality in above parts outside and inside, during periodic inspection. No Obvious Abrasion. No damage.
<input type="radio"/>		Load Sheave Sheave (Idler Sprocket Wheel of Bottom Hook for 6.3t)		No Obvious Abrasion or Deformation. No Crack or Damage.
<input type="radio"/>	<input type="radio"/>	Lever	Visual Inspection	No Obvious Deformation, Abrasion, Corrosion, Crack or other Harmful Defects.
<input type="radio"/>	<input type="radio"/>	Change Claw	Visual Inspection or Measurement after Disassembly	No Obvious Abrasion or Corrosion.
	<input type="radio"/>	Grip Ring	Visual Inspection or Measurement after Disassembly	No Obvious Abrasion and Damage or Corrosion of Screw Thread. No Harmful Defects such as Abrasion, Crack or Damage. No Obvious Abrasion. No Obvious Abrasion, Corrosion or Damage. No Harmful Defects in Use.
	<input type="radio"/>	Pinion		
	<input type="radio"/>	Hub		
	<input type="radio"/>	Change Gear		
	<input type="radio"/>	Shaft Bearing		
	<input type="radio"/>	Brake Van		
	<input type="radio"/>	Claw and Latchet Gear		
	<input type="radio"/>	Others		

* Be sure to check that it works smoothly while loaded, after it is disassembled and assembled.

Limit Dimension of Load Chain (mm)

Load Rating	Chain Diameter	Pitch P	5 Link (long) Standard	Dimension Limit Dimension
0.8t	6.3	19.0	95.5	97.0
1t				
1.6t	7.1	21.0	105.0	107.0
3.2t	9.0	27.0	135.0	138.0
6.3t				

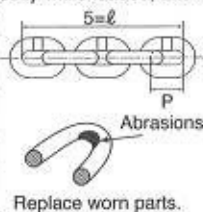

Limit Dimension of Hook (mm)

Load Rating	Dimension of Opening of Hook Standard	Limit Dimension
0.8t	27	29.6
1t	30	32.9
1.6t	34	37.5
3.2t	43	47.5
6.3t	47	52



Do not use an elongated hook which separated the safety clasp.