



Pacific Hoists

PACIFIC CHAIN BLOCKS WITH OPTIONAL OVERLOAD PROTECTION

Pacific Chain Blocks feature better quality in a new compact design. The extensive range is suitable for many applications in the mining, construction, industrial and automotive industry. A patented Overload Limiting device is available for all sizes (except for 250kg capacity) to improve safety. These chain blocks have it all; better quality, easy to use, improved safety and all of this with reduced cost.

Features

- All Pacific models are manufactured to comply with AS1418.2.
- High strength end stop with secondary end anchor for increased safety.
- “T” type hooks for improved load holding integrity (except for the 250kg capacity).
- Gear system design for reduced effort when lifting loads.
- Includes a specially designed hand wheel to eliminate hand chain slippage and pocket wear.
- Encapsulated needle bearings and side plate bearings for smoother operation.
- Brake lockout bearing for security of braking mechanism.
- Key internal components are CNC machined before being heat-treated and toughened.
- Fitted with high quality European zinc plated Grade 80 load chain.
- No aluminum content which ensures suitability for mining applications.
- Overall better design and improved finish to prolong life expectancy.
- All models available with a patented Overload Limiting device (except for the 250kg capacity).
- Now available with a complimentary display stand when purchasing a product stock package. For more information, please contact your Pacific Hoists representative or refer to page 3.



Specifications

CAPACITY	250 KG		500 KG		1 TONNE		1.5 TONNE		2 TONNE		3 TONNE		5 TONNE		10 TONNE	
Stock Code PCB	301	302	303	306	313	316	318	319	323	326	333	336	353	356	359	360
Lift Height (m)	3	6	3	6	3	6	3	6	3	6	3	6	3	6	3	6
Test Load (kg)	375		750		1500		2250		3000		4500		7500		15000	
Effort to lift full load (N)	190		210		285		325		355		340		400		540	
No. of Falls	1		1		1		1		1		2		2		4	
Hand Chain (mm x mm)	Ø5 x 23.7															
Hand Chain Drop (m)	2	5	2	5	2	5	2	5	2	5	2	5	2	5	2	5
Load Chain (mm x mm)	Ø4 x 12		Ø5 x 15		Ø6.3 x 19		Ø7.1 x 21		Ø8 x 24		Ø7.1 x 21		Ø9 x 27		Ø9 x 27	
Net Weight for 3m lift (kg)	6		9		12		14		20		23		39		65	
Stock Code with O/L PCB	301L	302L	303L	306L	313L	316L	318L	319L	323L	326L	333L	336L	353L	356L	359L	360L

*Pacific chain blocks with customised lift heights are available

Dimensions (in mm)

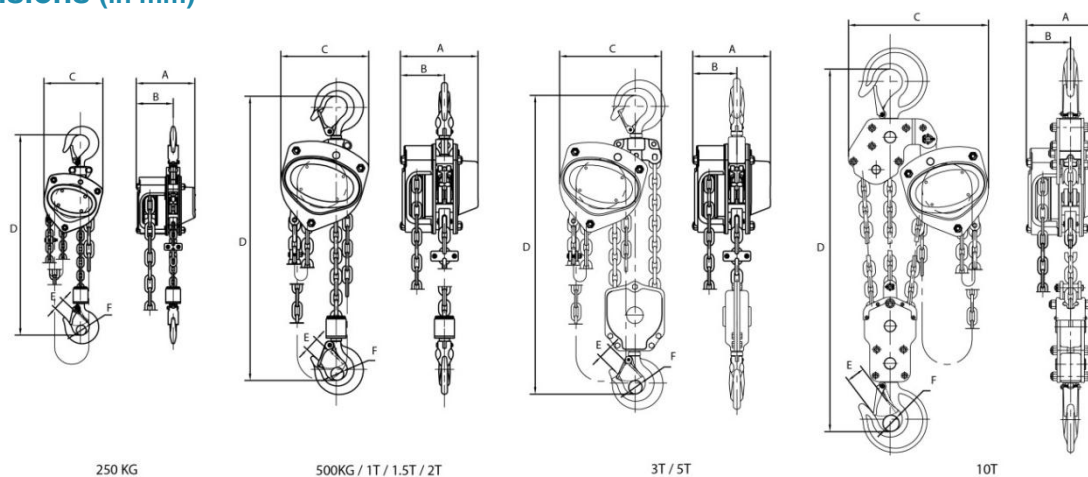

MODEL	250KG	500KG	1 TONNE	1.5 TONNE	2 TONNE	3 TONNE	6 TONNE	10 TONNE
A	106	128	142	158	175	158	183	195
B	68	75	76	80	88	80	90	95
C	108	130	150	170	185	220	225	355
D	280	280	330	360	385	510	615	810
E	20	22	26	29	35	37	43	47
F	Ø18	Ø20	Ø25	Ø30	Ø33	Ø36	Ø43	Ø44



The information shown is to be used as a guide only. Specifications are subject to change without notice. All materials handling or lifting jobs should be assessed individually. Pacific Hoists products are NOT to be used for lifting or lowering persons.

HEAD OFFICE

24 Foundry Rd,
Seven Hills NSW 2147 Australia
P +61 2 8825 6900
F +61 2 8825 6999
E sales@pacifichoists.com.au

WESTERN AUSTRALIA

Unit 1, 31 Colin Jamieson Drive,
Welshpool WA 6106
P +61 8 6253 1000
F +61 8 9458 9840
E sales@pacifichoists.com.au

QUEENSLAND

5/54 Nealdon Drive,
Meadowbrook QLD 4131
P +61 7 3170 3800
F +61 7 3170 3811
E sales@pacifichoists.com.au

NEW ZEALAND

11 Druces Rd,
Manukau City 2104 Auckland
P +64 9 263 5566
F +64 9 263 5567
E info@pacifichoists.co.nz

PACIFIC PRODUCT DISPLAY STAND

With the purchase of one of our product stock packages, you are entitled to a complimentary Pacific Product Display Tripod Stand; made from quality steel. It features lockable castor wheels for ease of movement and safety while on display. The Pacific Hoists signage includes a QR code for quick access to product features, specifications and line drawings. The stand allows for the display of chain blocks, lever blocks, trolleys and clamps.

Features

- Tripod stand made from quality steel.
- Inclusive of lockable castor wheel for ease of movement and safety while on display.
- This display stand is collapsible by unbolting the screws.
- Pacific Hoists signage which includes a QR code for quick access to product features, specifications and line drawings.
- For the display of a variety of chain and lever blocks, trolleys and clamps.
- Contact your Pacific Hoists representative to discuss your stock requirements. The package must consist of Pacific GEN III chain blocks or lever blocks, Pacific trolleys and clamps. An example of such package can be 1x PCB303, 1x PCB313, 2x PCB313L, 2x PCB316L, 1x PLB302, 1x PLB308L, 1x PLB316L, 2x PGC310 and 2x PPT105.*

*The display stand is offered as part of this package for the sole purpose of display of products offered by Pacific Hoists.

Specifications & Dimensions

PRODUCT CODE	STAND
Height (m)	220
Width (m)	140
Depth (m)	140
Weight; excl. products (kg)	25



The information shown is to be used as a guide only. Specifications are subject to change without notice. All materials handling or lifting jobs should be assessed individually. Pacific Hoists products are NOT to be used for lifting or lowering persons.

HEAD OFFICE

24 Foundry Rd,
Seven Hills NSW 2147 Australia
P +61 2 8825 6900
F +61 2 8825 6999
E sales@pacifichoists.com.au

WESTERN AUSTRALIA

Unit 1, 31 Colin Jamieson Drive,
Welshpool WA 6106
P +61 8 6253 1000
F +61 8 9458 9840
E sales@pacifichoists.com.au

QUEENSLAND

5/54 Nealdon Drive,
Meadowbrook QLD 4131
P +61 7 3170 3800
F +61 7 3170 3811
E sales@pacifichoists.com.au

NEW ZEALAND

11 Druces Rd,
Manukau City 2104 Auckland
P +64 9 263 5566
F +64 9 263 5567
E info@pacifichoists.co.nz