

VITAL Chain Block

HEAVY DUTY chain blocks suitable for many applications in the industrial, rural, construction and mining industries

Features

- Made in Japan from optimum high quality steel to conform to the strict J.I.S and I.S.O regulations.
- Designed for long term use providing the lowest possible per-use cost.
- Quality caged needle bearings on load sheave and thrust bearings on the bottom hook.
- Hardened special alloy steel load chain with embossed identification marked as to relevant standards.
- Vital have been manufacturing chain blocks since 1933 and is recognised globally.
- Fitted with Grade 100 load chain.

Optional Extra

Vital Chain Blocks can now be fitted with overload protection.



www.pacifichoists.com.au

Applications

The chain block is commonly used in the construction, industrial, mining, rural and automotive industries. An economical method to lift very heavy loads with ease.



Dimensions and Specifications

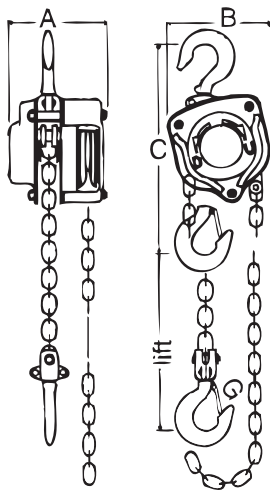

Coupled to Trolleys

Vital Chain Blocks can be coupled to trolleys to reduce headroom

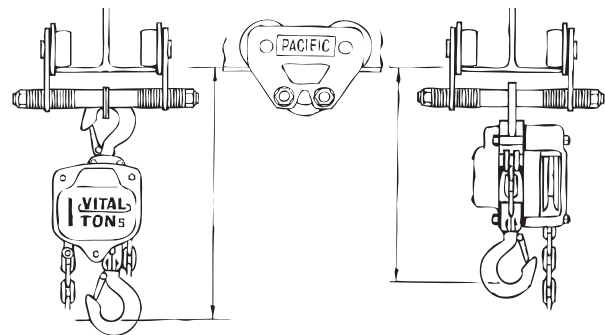

Model	05VH5	10VH5	15VH5	20VH5	30VH5	50VH5	75VH5	90VH5	92VH5	93VH5
Stock Code	VCB050	VCB100	VCB150	VCB200	VCB300	VCB500	VCB750	VCB910	VCB915	VCB920
Rated Capacity tonne	0.5	1.0	1.5	2.0	3.0	5.0	7.5	10	15	20
Standard Lift m	3	3	3	3	3	3	3	3	3	3
Pull to Lift Load kg	25	33	34	34	35	39	41	41	41x2	41x2
Net Weight kg	8.6	11.5	13.8	21.6	23	41	60.5	78	150	190
Dimensions A mm	127	147	147	179	147	179	179	179	207	207
B mm	144	157	174	204	206	263	345	367	745	873
G mm	27	30	34	37	43	47	67	67	87	87
Headroom C mm	305	345	370	425	505	635	740	760	850	870

*Chain Blocks with customised lifts heights also available

Your nearest distributor;

The information contained in this flyer is to be used as a guide only, specifications subject to change without notice. All Materials Handling/Lifting jobs should be assessed individually. Pacific Hoists products are NOT to be used for lifting or lowering person/s.

PACIFIC HOISTS PTY LTD

www.pacifichoists.com.au



Head Office
 24 Foundry Road
 Seven Hills NSW 2147
 Tel: +61 2 8825 6900
 Fax: +61 2 8825 6999
 Email: sales@pacifichoists.com.au

Western Australia
 3/39 Tullock Way
 Canning Vale WA 6155
 Tel: +61 8 9456 4140
 Fax: +61 8 9456 4142
 Email: sales@pacifichoists.com.au

New Zealand
 11 Druces Road
 Manukau City South Auckland
 New Zealand
 Tel: +64 9 263 5566
 Fax: +64 9 263 5567
 Email: info@pacifichoists.co.nz

