

JDN mini Air Hoist

With its patented motor brake system and robust aluminium housing the JDN mini consists of only a few components resulting in low and easy maintenance. Due to its small headroom and light weight the JDN mini is easy to handle and move around.

Features

- Manufactured in Germany under strict quality control with demanding tolerances.
- Low maintenance design delivers 100% duty cycle in all environmental conditions.
- Insensitive to dust, humidity & temperatures from – 20°C up to approx. +50°C.
- Only six atmospheres of compressed air required.
- Suitable for application in hazardous areas and horizontal pulling.
- Self-cooling air motor that will not overheat.
- Fail safe brake in case of air supply failure.
- Sensitive infinitely variable speed control for the precise positioning of loads.



Example of mini with Manipulator used for precision movements available in the 125/250 models



Applications



JDN mini 250 holding machine parts in processing plant.



Convenient carry case available as an optional extra for the mini 125 and mini 250 models.

Dimensions

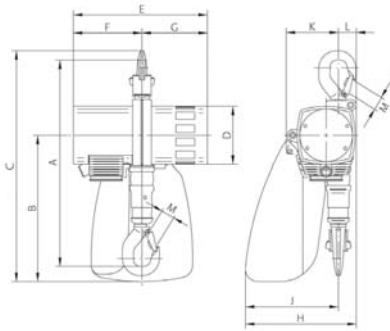

Model	MINI125	MINI250	MINI500	MINI1000
Dimensions mm C	232	232	316	316
E	213	213	292	292
H	177	177	238	234
J	148	148	194	194
M	19	19	28	28
Headroom A	328	328	458	458

Specifications

Model	MINI125	MINI250	MINI500	MINI1000
Rated Capacity kg	125	250	500	1000
Stock code	JDN123	JDN253	JDN503	JDN603
Weight at standard 3m lift kg	9.5	10.5	21	23
Motor output kW	0.4	0.4	1.0	1.0
Chain dimension mm	4x12	4x12	7x21	7x21
Air pressure bar	6	6	6	6
Air consumption at full load m ³ /min	0.5	0.5	1.2	1.2
Lowering	0.7	0.7	1.6	1.6
Air connection	G ³ / ₈	G ³ / ₈	G ¹ / ₂	G ¹ / ₂
Lifting speed at full load m/min	15	8	10	5
Lowering speed at full load m/min	30	16	18	10

* Custom lift heights also available. Weight and headroom based on Mini standard model with pendant control and chain bucket.

Your nearest distributor;

The information contained in this flyer is to be used as a guide only, specifications subject to change without notice. All Materials Handling/Lifting jobs should be assessed individually. Pacific Hoists products are NOT to be used for lifting or lowering person/s.



PACIFIC HOISTS PTY LTD

www.pacifichoists.com.au

Head Office
24 Foundry Road
Seven Hills NSW 2147
Tel: +61 2 8825 6900
Fax: +61 2 8825 6999
Email: sales@pacifichoists.com.au

Western Australia
3/39 Tullock Way
Canning Vale WA 6155
Tel: +61 8 9456 4140
Fax: +61 8 9456 4142
Email: sales@pacifichoists.com.au

New Zealand
11 Druces Road
Manukau City South Auckland
New Zealand
Tel: +64 9 263 5566
Fax: +64 9 263 5567
Email: info@pacifichoists.co.nz

