

Pacific Capstan Winch

The Pacific Capstan Winch is suitable for tackling the toughest wall, ground and underground pulling applications.

Features

- 240 volt single phase cable puller.
- Dual pulling capacity of 2500 kg and 1500 kg.
- Over load protection switch.
- Electromagnetic spring-applied fail safe brake.
- Heavy duty high efficiency ball bearings on all running surfaces.
- Case hardened gear train for maximum mechanical efficiency.
- Rope storage reeler.

Foot Control for ease of operation



www.pacifichoists.com.au

Applications



Dimensions

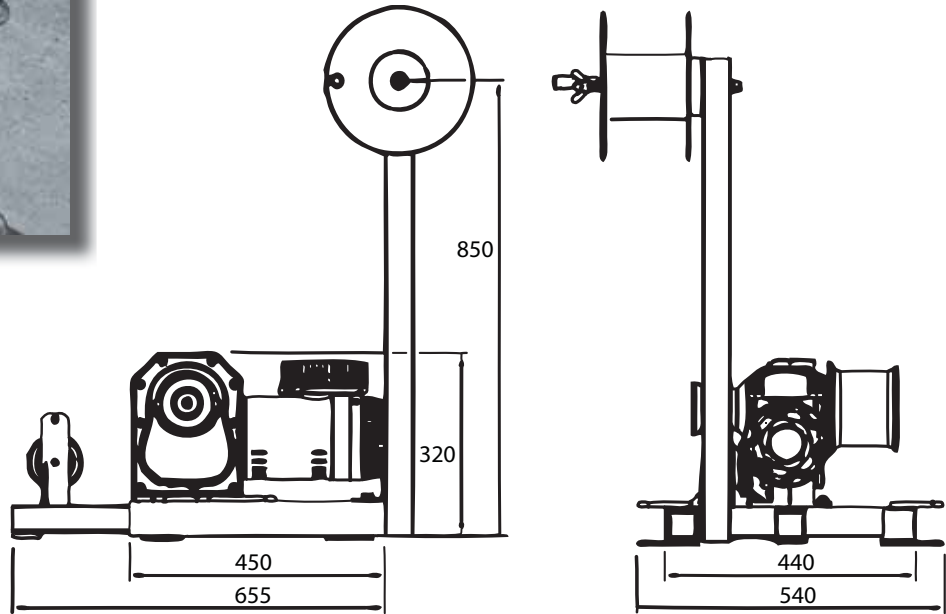

Specifications

Model	H -2500	
Stock Code	CAP250	
Pulling capacity	kg	1500 / 2500
Max pulling duration	min	15
Speed	m/min	4.0 / 2.5
Control	Foot Control	
Gear Ratio	154:1	
Net Weight	kg	60

 A minimum of six (6) wraps of rope around the drum is necessary to support the rated load.

Do not use the Capstan Winch as a lifting device or for vertical lifting

Your nearest distributor;

The information contained in this flyer is to be used as a guide only, specifications subject to change without notice. All Materials Handling/Lifting jobs should be assessed individually. Pacific Hoists products are NOT to be used for lifting or lowering person/s.

PACIFIC HOISTS PTY LTD

www.pacifichoists.com.au



Head Office
24 Foundry Road
Seven Hills NSW 2147
Tel: +61 2 8825 6900
Fax: +61 2 8825 6999
Email: sales@pacifichoists.com.au

Western Australia
3/39 Tullock Way
Canning Vale WA 6155
Tel: +61 8 9456 4140
Fax: +61 8 9456 4142
Email: sales@pacifichoists.com.au

New Zealand
11 Druces Road
Manukau City South Auckland
New Zealand
Tel: +64 9 263 5566
Fax: +64 9 263 5567
Email: info@pacifichoists.co.nz

